



FUSION 4

MODULAR GYM SYSTEM

LOWER BODY UNIT

OWNER'S MANUAL



SERIAL NUMBER HERE

DATE OF PURCHASE



BATCA
fitness systems . usa

INSTRUCTIONS

CONGRATULATIONS ON THE PURCHASE OF YOUR NEW FUSION 4 LOWER BODY STATION. THIS GYM WILL PROVIDE YOU WITH A LIFETIME OF ENJOYMENT TO MEET YOUR STRENGTH TRAINING NEEDS. BATCA FITNESS SYSTEMS STRIVES TO BUILD THE BEST QUALITY MULTI-STATION GYMS AND TO PACKAGE THESE GYMS IN SUCH A WAY TO AVOID ANY DAMAGE DURING SHIPPING.

IN ORDER TO GET STARTED WITH YOUR ASSEMBLY YOU SHOULD FIRST FAMILIARIZE YOURSELF WITH THIS MANUAL. IT IS RECOMMENDED THAT YOU READ THROUGH EACH STEP THOROUGHLY BEFORE YOU BEGIN. BEGIN BY OPENING YOUR BOXES AND SEPARATING ALL OF YOUR PARTS. VERIFY THAT ALL PARTS ARE ACCOUNTED FOR AND HAVE NO DAMAGE. WHEN ALL PARTS ARE ACCOUNTED FOR, YOU MAY BEGIN YOUR ASSEMBLY. SOME ITEMS MAY HAVE BEEN PRE-ASSEMBLED FOR YOUR CONVENIENCE. PLEASE NOTE THAT HARDWARE QUANTITIES SHOWN REFLECT TOTAL QUANTITIES FOR YOUR GYM AND MAY NOT REFLECT ACTUAL QUANTITIES IN EACH BAG. ASSEMBLE YOUR GYM ON A SOLID LEVEL SURFACE. THIS WILL ENSURE THE BEST POSSIBLE PERFORMANCE, FUNCTION, AND SAFETY FOR THE GYM AND YOUR WORKOUT.

ASSEMBLE YOUR GYM ACCORDING TO THE STEP BY STEP INSTRUCTIONS FOUND IN THIS MANUAL. FAILURE TO DO SO WILL VOID YOUR WARRANTY AND MAY RESULT IN PERSONAL INJURY. AFTER ASSEMBLY, YOU SHOULD CHECK EACH STATION TO ENSURE CORRECT OPERATION. IF A PROBLEM ARISES, RECHECK YOUR ASSEMBLY WITH THESE INSTRUCTIONS TO VERIFY CORRECT ASSEMBLY. IF YOU ARE UNABLE TO CORRECT A PROBLEM OR HAVE QUESTIONS WITH YOUR ASSEMBLY PLEASE CONTACT YOUR AUTHORIZED BATCA DEALER.

WARNING

BATCA FITNESS SYSTEMS HAS BUILT THIS GYM TO GIVE YOU A SAFE, EFFECTIVE AND ENJOYABLE WORKOUT. HOWEVER, THERE IS A RISK ASSUMED BY INDIVIDUALS WHO USE THIS TYPE OF EQUIPMENT. IT IS VERY IMPORTANT THAT ALL WARNINGS AND INSTRUCTIONS ARE READ AND FOLLOWED BEFORE BEGINNING ANY EXERCISE PROGRAM.

IT IS ALSO VERY IMPORTANT TO READ AND FOLLOW THE PREVENTATIVE MAINTENANCE SCHEDULE DESCRIBED IN THIS MANUAL. IF ANY OF THE WARNING LABELS OR STICKERS ARE WORN, FADED, TORN, SCRATCHED OR MISSING THEY SHOULD BE REPLACED IMMEDIATELY.

WARNING: THERE IS A RISK ASSUMED BY INDIVIDUALS WHO USE THIS TYPE OF EQUIPMENT. TO MINIMIZE RISK ALWAYS FOLLOW THESE RULES.

- 1) IT IS ESSENTIAL THAT YOU CONSULT WITH YOUR PHYSICIAN BEFORE BEGINNING ANY EXERCISE PROGRAM.
- 2) INSPECT EQUIPMENT BEFORE EACH USE FOR LOOSE, WORN, OR FRAYED PARTS (INCLUDING CABLES, NUTS AND BOLTS). REPLACE PARTS AT FIRST SIGNS OF WEAR (USE ONLY GENUINE BATCA REPLACEMENT PARTS). USE OF EQUIPMENT THAT IS DAMAGED, WORN, FRAYED OR NOT COMPLETELY ASSEMBLED ON A SOLID, LEVEL SURFACE MAY RESULT IN INJURY.
- 3) MAKE SURE ALL ADJUSTMENT PINS ARE FULLY ENGAGED BEFORE USING EQUIPMENT.
- 4) KEEP ALL PARTS OF THE BODY AND CLOTHING OUTSIDE THE PATH OF ANY MOVING PARTS OF THE GYM. BE ALERT TO THE POSSIBILITY OF INJURY. DO NOT BE CARELESS.
- 5) MINORS AND CHILDREN SHOULD NOT BE ALLOWED TO PLAY ON OR AROUND THIS GYM.
- 6) IF YOU HAVE ANY QUESTIONS ON PROPER USE OR MAINTENANCE OF THIS GYM, DO NOT HESITATE TO CALL YOUR LOCAL BATCA FITNESS SYSTEMS DISTRIBUTOR OR BATCA FITNESS SYSTEMS AT (919) 255-1233. WWW.BATCAFITNESS.COM

TABLE OF CONTENTS

	<u>PAGE</u>		<u>PAGE</u>
INSTRUCTIONS	2	LEG PRESS CABLE ROUTING	24-25
PARTS LISTING	3-5	WEIGHT STACK DECALS AND SERIAL NUMBER	26
HARDWARE COMPARISON	6-9	CABLE TENSION, ADJUSTMENT, AND COMPARISON	27-29
MAIN FRAME ASSEMBLY	10-14	FINAL ASSEMBLY AND TROUBLESHOOTING	30
CABLE ROUTING	15-18	MAINTENANCE	31
UPHOLSTERY	19-20	WARRANTY	32
LEG PRESS OPTION	21-25	FLOOR PLAN LAYOUT	33-34

FRAME COMPONENTS

ITEM NO.	PART NO.	DESCRIPTION	QTY
1	BFM-10747	RIGHT AND LEFT VERTICAL SUPPORT	2
2	BFM-10765	MIDDLE BASE	1
3	BFM-10593	REAR BASE	1
4	BFM-10744	UPPER FRAME	1
5	BFM-10769	LARGE FLAT LEVELER	2
6	BFM-51490	GUIDE ROD HOLDER	1
7	BFM-51082	SHROUD	1
8	BFM-51051	GUIDE ROD	2
9	BFM-50256	WEIGHT PLATE	19
10	BFM-50529	RUBBER DONUT	2
11	BFM-10299	TOP WEIGHT PLATE	1
12	BFM-10581	LEG EXTENSION CURL FRAME	1
13	BFM-51143	8" ANTI DEFLECTION PLATE	1
14	BFM-10141	KNEE ALIGNMENT ROLLER	1
15	BFM-10584	LEG EXTENSION SHAFT	1
16	BFM-10585	LEG EXTENSION CAM ASSEMBLY	1
17	BFM-50222	AXLE	1

ITEM NO.	PART NO.	DESCRIPTION	QTY
18	BFM-10742	LEG EXTENSION ARM ASSEMBLY	1
19	BFM-10587	KNEE HOLD DOWN ASSEMBLY	1
20	BFM-51094	AXLE	1
21	BFM-10611	CRISS-CROSS FREE FLOATER	1
22	BFM-10610	LOWER PULLEY HOLDER	2
23	BFM-10612	CABLE TIE OUT PLATE	1
24	BFM-50505	3-1/2 PULLEY COVER	1
25	BFM-51158	SPACER	1
26	BFM-10588	KNEE HOLD DOWN HANDLE	1
27	BFM-51382	6" COUNTER WEIGHT	1
28	BFM-10768	RIGHT HANDLE	1
29	BFM-10767	LEFT HANDLE	1
30	BFM-10580	BACK CHROME ADJUSTMENT	1
31	BFL-50274	KNEE HOLD DOWN ADJUSTMENT PLATE	1
32	BFL-50211	T-SHAPED PLATE	1
33	BFL-50203	PULLEY HOLDER CONNECTOR PLATE	1
34	BFL-50221	3-1/2" DOUBLE PULLEY COVER	1
125	BFM-52410	FRONT SHROUD	1

ACCESSORIES

ITEM NO.	PART NO.	DESCRIPTION	QTY
35	BFM-51173	WEIGHT STACK PIN	1

UPHOLSTERY

ITEM NO.	PART NO.	DESCRIPTION	QTY
36	BFP-52130	LARGE BOTTOM PAD	1
37	BFP-52137	HEAD PAD	1
38	BFP-52136	BACK PAD WITH LUMBAR	1
39	BFU-10122	LARGE ROLLER	1
40	BFU-10121	7" ROLLER	4

CABLES

ITEM NO.	PART NO.	DESCRIPTION	QTY
41	CAB-13022	WEIGHT STACK TO CABLE TIE OUT	1
42	CAB-13028	FUSION FREE FLOATER CABLE	1
43	CAB-13026	FUSION TIE OUT CABLE	1
44	CAB-13029	FUSION LEG EXTENSION CABLE	1

HARDWARE

ITEM NO.	PART NUMBER	DESCRIPTION	QTY
45	BFP-52394	SHCS 3/8"-16 x 2-1/2"	3
46	BFP-51653	SHCS 3/8"-16 x 1-1/4"	4
47	BFP-51799	SHCS 3/8"-16 x 5"	4
48	BFP-51756	SHCS 3/8"-16 x 5-1/4"	4
49	BFH-50630	FHSCS 3/8"-16 x 3/4"	2
50	BFP-52420	BHSCS 3/8" x 2"	1
51	BFP-52340	SHCS 3/8"-16 x 3/4"	2
52	BFH-50144	FHSCS 3/8"-16 x 1"	2
53	BFP-52396	SHCS 3/8"-16 x 5-1/2"	2
54	BFH-50165	1" SNAP RING	2
55	BFH-50337	WAVY WASHER	3
56	BFP-52401	BHSCS 3/8"-16 x 1/2"	4
57	BFH-50245	FHSCS 5/16"-18 x 1"	2
58	BFP-51747	SHCS 3/8"-16 x 3"	5
59	BFH-50174	4-1/2" PULLEY	4
60	BFH-50173	3-1/2 PULLEY	7
61	BFH-50267	5/16" NYLOCK	2
62	BFP-51752	SHCS 3/8"-16 x 2-1/4"	9
63	BFH-50250	1-1/4" SHOULDER BOLT	2
64	BFP-52397	SHCS 3/8"-16 x 1-3/4"	2
65	BFH-50605	3/8" PULLEY SPACER	2
66	BFH-50622	UPHOLSTERY CAP	4
67	BFH-50221	3" PLASTIC WASHER	4
68	BFP-51759	HCS 3/8"-16 x 2"	1
69	BFH-50204	CURVED WASHER	4
70	BFP-52524	SHCS 3/8"-16 x 6 1/4"	1
71	BFP-51750	SHCS 3/8"-16 x 2-3/4"	2
72	BFP-51748	SHCS 3/8"-16 x 3-1/4"	2
73	BFH-50146	3/8" FLAT WASHER	70
74	BFH-50157	3/8" NYLOCK	31
75	BFH-50147	3/8" LOCK WASHER	17
76	BFH-50192	WEIGHT STACK DECALS	1
77	BFH-50262	SILICON GEL PACK	1
99	BFP-52430	BHSCS 3/8-16 x 3/4"	4
126	BMF-52422	RED PIVOT POINT CAP	1
127	BFH-50620	BHSCS 3/8" x 1"	1

LEG PRESS COMPONENTS

ITEM NO.	PART NUMBER	DESCRIPTION	QTY
76	BFM-10575	LEG PRESS CONNECTOR	1
77	BFM-11042	LEG PRESS FRAME	1
78	BFM-11034	FOUR BAR	2
79	BFM-52449	FOUR BAR SPACER	2
80	BFM-11035	LEG PRESS PIVOT ARM	1
81	BFP-51844	1" SHAFT	2
82	BFP-51846	3/4" SHAFT	2
83	BFM-11036	LEG PRESS FOOT PLATE	1

ITEM NO.	PART NUMBER	DESCRIPTION	QTY
84	BFM-11040	RIGHT HANDLE	1
85	BFM-11041	LEFT HANDLE	1
86	BFM-10106	BACK ADJUSTMENT TUBE	1

LEG PRESS HARDWARE

ITEM NO.	PART NUMBER	DESCRIPTION	QTY
87	BFP-51696	SMALL ALUMINUM END CAP	2
88	BFH-50173	3 1/2" PULLEY	5
89	BFH-50605	3/8" PULLEY SPACER	5
90	BFP-51700	BHSCS 3/8" x 1"	4
91	BFH-50351	1 3/8" SHOULDER BOLT	1
92	BFP-51653	SHCS 3/8" x 1 1/4"	2
93	BFP-52397	SHCS 3/8" x 1 3/4"	1
94	BFP-51759	SHCS 3/8" x 2"	2

ITEM NO.	PART NUMBER	DESCRIPTION	QTY
95	BFP-52394	SHCS 3/8" x 2 1/2"	2
96	BFP-51750	SHCS 3/8" x 2 3/4"	2
97	BFP-51756	SHCS 3/8"-16 X 5 1/4"	4
98	BFM-50267	5/16 NYLOCK	1
99	BFH-50147	3/8" LOCK WASHER	4
100	BFH-50146	3/8" FLAT WASHER (BLACK)	24
101	BFH-50157	3/8"-16 NYLOCK (BLACK)	10
105	BFP-51747	3/8"-16 x 3"	2

CABLES

ITEM NO.	PART NUMBER	DESCRIPTION	QTY
102	CAB-13023	FUSION LEG PRESS CABLE	1

UPHOLSTERY

ITEM NO.	PART NUMBER	DESCRIPTION	QTY
103	BFP-52130	LARGE BOTTOM PAD	1
104	BFP-52136	BACK PAD WITH LUMBAR	1

TOOLS REQUIRED

- 1/2" WRENCH
- 9/16" WRENCH
- 9/16" RATCHET
- 3/4" WRENCH
- 3/4" RATCHET
- ALLEN WRENCH SET
- TAPE MEASURE
- SNAP RING PLIERS

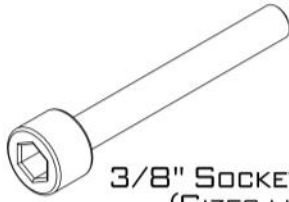

3/8" SOCKET HEAD CAP SCREW
(SIZES LISTED IN CHART)

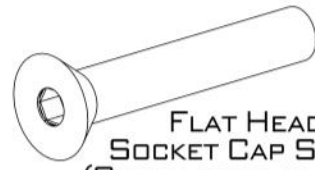

FLAT HEAD SOCKET CAP SCREW
(SIZES LISTED IN CHART)

PART #	BOLT SIZE
BFP-52340	3/8" x 3/4"
BFP-52376	3/8" X 1"
BFP-51653	3/8" x 1 1/4"
BFP-51697	3/8" x 1 1/2"
BFP-51759	3/8" x 2"
BFP-51752	3/8" x 2 1/4"
BFP-51750	3/8" x 2 3/4"
BFP-51747	3/8" x 3"
BFP-51748	3/8" x 3 1/4"
BFP-51760	3/8" x 3 1/2"
BFP-52345	3/8" x 4"
BFP-51884	3/8" X 4 1/4"
BFP-51751	3/8" x 4 1/2"
BFP-51753	3/8" x 4 3/4"
BFP-51799	3/8" x 5"
BFP-51756	3/8" x 5 1/4"
BFP-52364	3/8" x 6"

PART #	BOLT SIZE
BFH-50144	FHSCS 3/8"-16 x 1"
BFP-52377	FHSCS 3/8" x 2"
BFH-50145	FHSCS 3/8"-16 x 2 1/4"
BFP-52374	FHSCS 3/8" x 2 3/4"

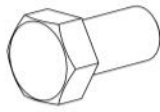

HEX HEAD CAP SCREW (HCS) 3/8" x 3/4"
(BFH-50254)

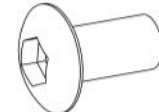

BUTTON HEAD SOCKET CAP SCREW (BHSCS) 3/8" x 3/4"
BFP-52430

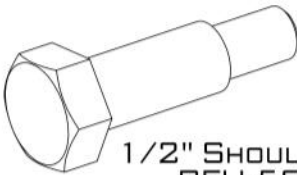

1/2" SHOULDER BOLT
BFH-50249

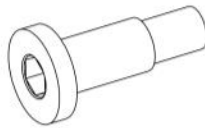

1 1/4" SHOULDER BOLT
BFH-50250



ZINC PLATED SHCS 5/16" x 1/2"
(BFP-52372)



5/16"-18 NYLOCK
BFH-50267



3/8"-16 THIN NYLOCK
BFH-50247



3/8"-16 NYLOCK
BFH-50157

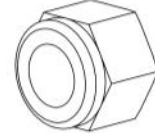

1/2"-13 NYLOCK
BFH-50251



1/2" JAM NUT
BFH-50256



3/8" JAM NUT
BFH-50149

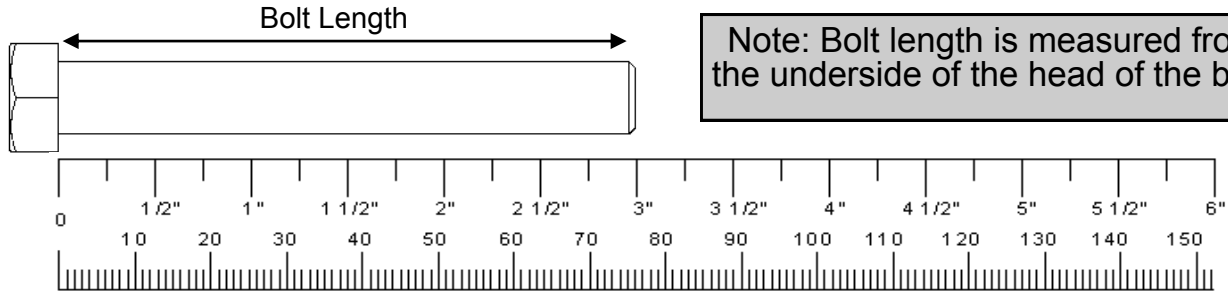

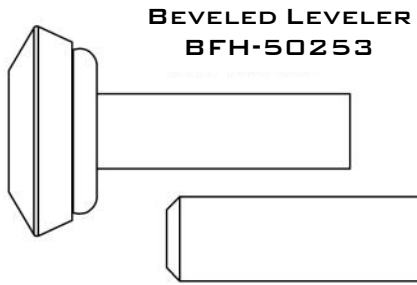

**BEVELED LEVELER
BFH-50253**



**LARGE FLAT LEVELER
BFH-50339**

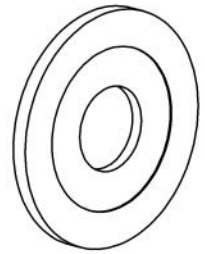

**3" PLASTIC
WASHER**

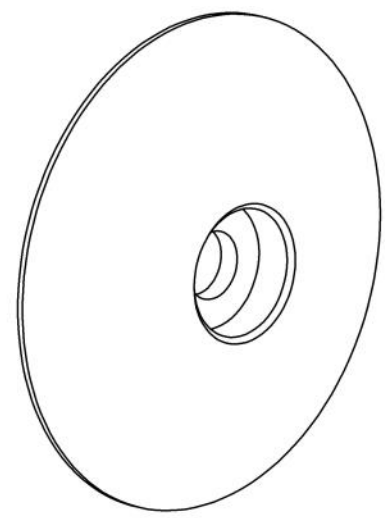

**UPHOLSTERY
CAP**

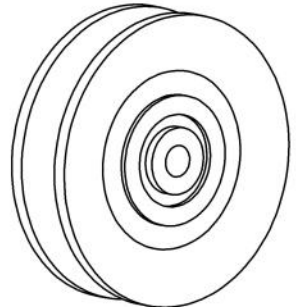

**3 1/2" PULLEY
BFH-50173**

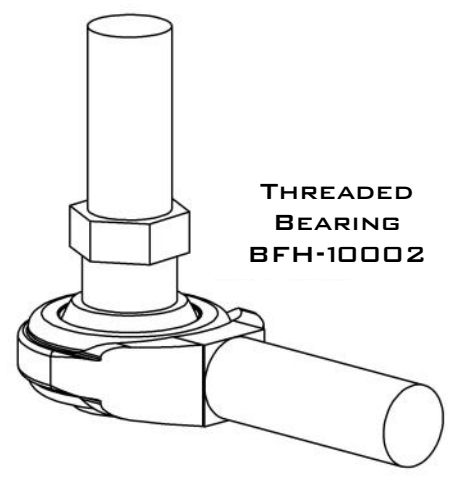

**THREADED
BEARING
BFH-10002**

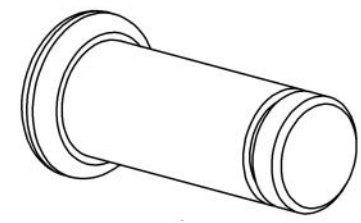

**PIN
BFH-50238**

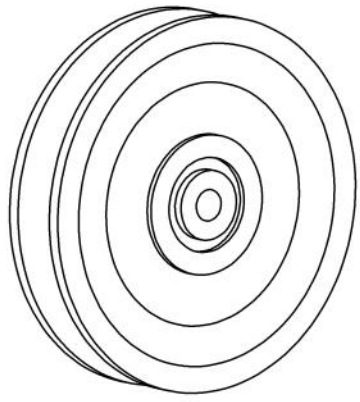

**4 1/2" PULLEY
BFH-50174**

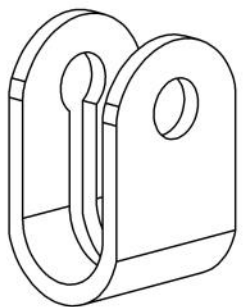

**CABLE STRAP
BFH-50227**

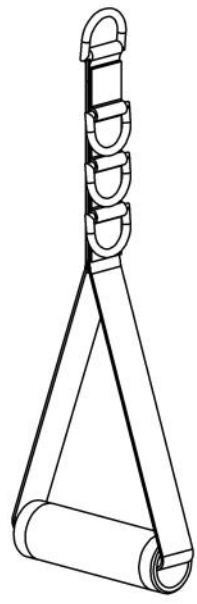

**STRAP HANDLE
BFC-10103**

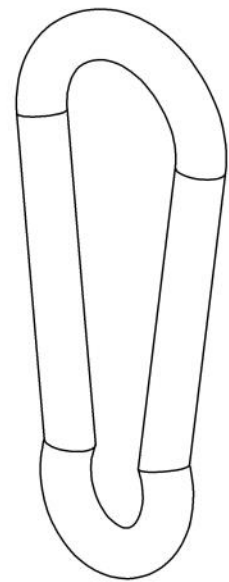

**SNAP HOOK
BFH-50188**

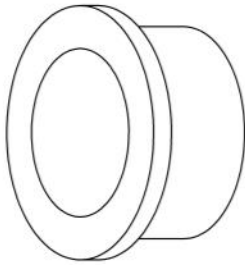

1" BRONZE BUSHING
BFH-50101

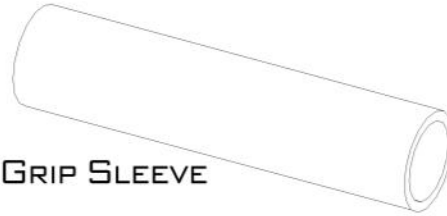

GRIP SLEEVE

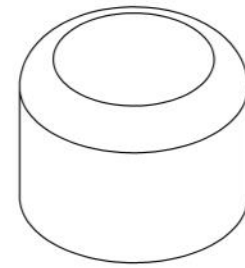

1" OUTER PLASTIC CAP
BFH-50111



GRIP CAP



GRIP COLLAR

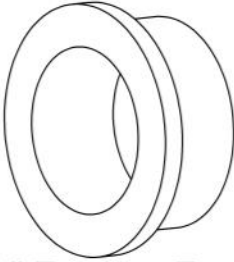

1" BRONZE BUSHING X 1/2 L
BFH-50297

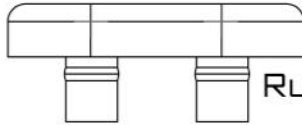

RUBBER BUMPERS
BFH-50222

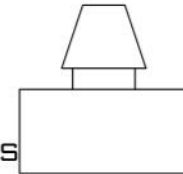

BFH-50200



5/8" BRONZE BUSHING
BFH-50102

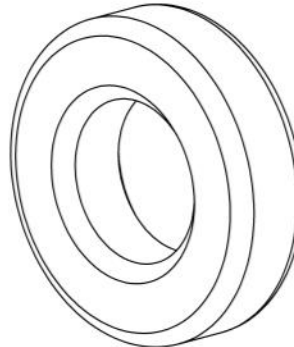

RADIAL BEARING
BFH-50602

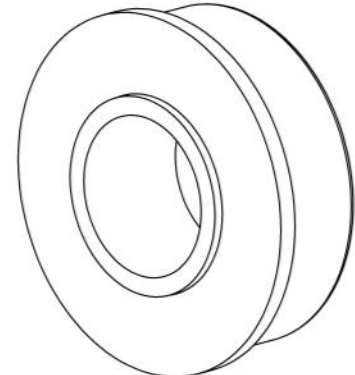

FLANGED RADIAL BEARING
BFP-51949

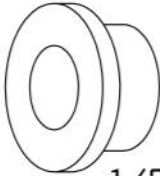

1/2" BRONZE BUSHING
BFH-50103



CABLE PIVOT BUSHING
BFH-50248

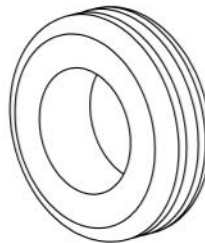

RUBBER GROMMET
BFH-50199



SHORT 1/2" BUSHING
BFH-50244



1/2" SNAP RING
BFH-50166

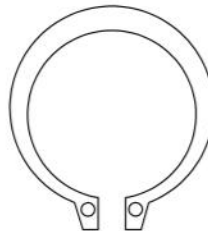

1" SNAP RING
BFH-50165

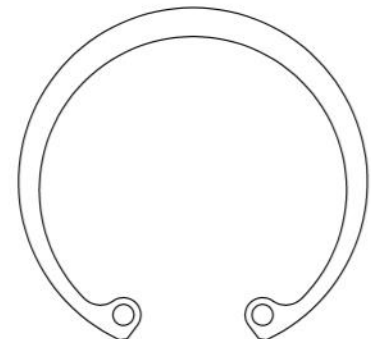

2 1/2" SNAP RING
BFH-50604

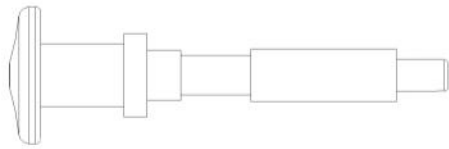

3/8" LONG PULL PIN
BFM-51176

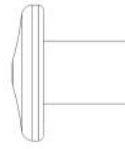

PULL PIN HANDLE
BFM-51181



PLASTIC END CAP
(BFP-52101)



1/2" LONG PULL PIN
BFM-51172



3/8" SHORT PULL PIN
BFM-51175

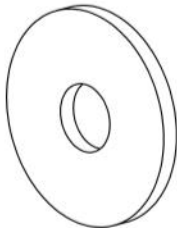

3/8" FENDER WASHER
BFH-50242

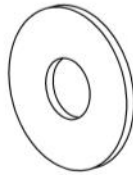

3/8" FLAT WASHER
BFH-50146



3/8" CURVED WASHER
BFH-50204

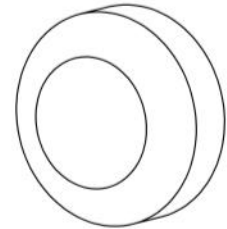

SCREW CAP COVER
BFH-50112

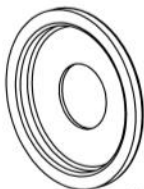

SCREW CAP WASHER
BFH-50113



3/8" LOCK WASHER
BFH-50147



MAGNETIC WEIGHT STACK PIN
BFM-51173

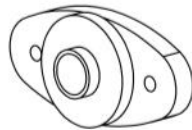

SIDE MOUNTED
FLANGE BEARING
BFH-50171

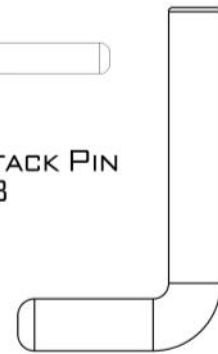

BAR CATCH RUBBER
SLEEVE
BFH-50240

ITEMS NOT SHOWN.

PART #	DESCRIPTION
BFH-50259	MIDNIGHT BLACK PAINT
BFH-50278	SILVER METALLIC PAINT
BFH-50198	LARGE LOGO
BFH-50236	FOAM GRIP
BFH-50262	SILICON GEL PACK
BFC-10101	1 INCH CHAIN
BFC-10102	12 INCH CHAIN

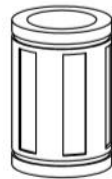

LINEAR BEARING
BFH-50627



BEARING RETAINING
CLIP
BFH-50628



PLEASE FOLLOW ALL DIRECTIONS VERY CAREFULLY FOR PROPER INSTALLATION.

STEP 1:



NOTE: FOR A MORE CONSISTENT APPEARANCE, POSITION ALL BOLTS IN THE DIRECTION SHOWN IN EACH

- **ALL FLAT WASHERS AND NYLOCKS ARE 3/8" UNLESS OTHERWISE NOTED.**

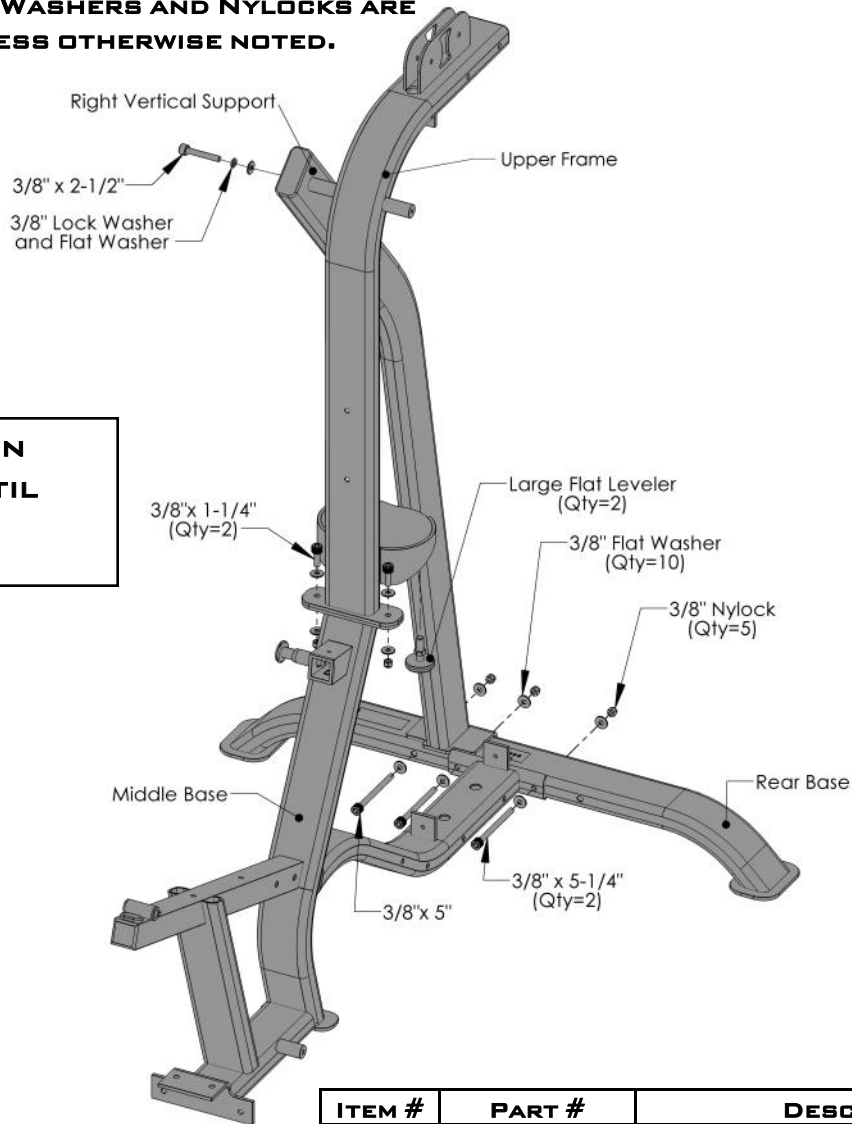

**DO NOT TIGHTEN
HARDWARE UNTIL
NEXT STEP**

FIGURE 1

ITEM #	PART #	DESCRIPTION	QTY
1	BFM-10747	RIGHT VERTICAL SUPPORT	1
2	BFM-10765	MIDDLE BASE	1
3	BFM-10593	REAR BASE	1
4	BFM-10744	UPPER FRAME	1
5	BFM-10769	LARGE FLAT LEVELER	2
45	BFP-52394	SHCS 3/8"-16 x 2 1/2	1
46	BFP-51653	SHCS 3/8"-16 x 1 1/4	2
47	BFP-51799	SHCS 3/8"-16 x 5"	1
48	BFP-51756	SHCS 3/8"-16 x 5 1/4"	2
73	BFH-50146	3/8" FLAT WASHER	11
74	BFH-50157	3/8" NYLOCK	5
75	BFH-50147	3/8" LOCK WASHER	1

STEP 2:

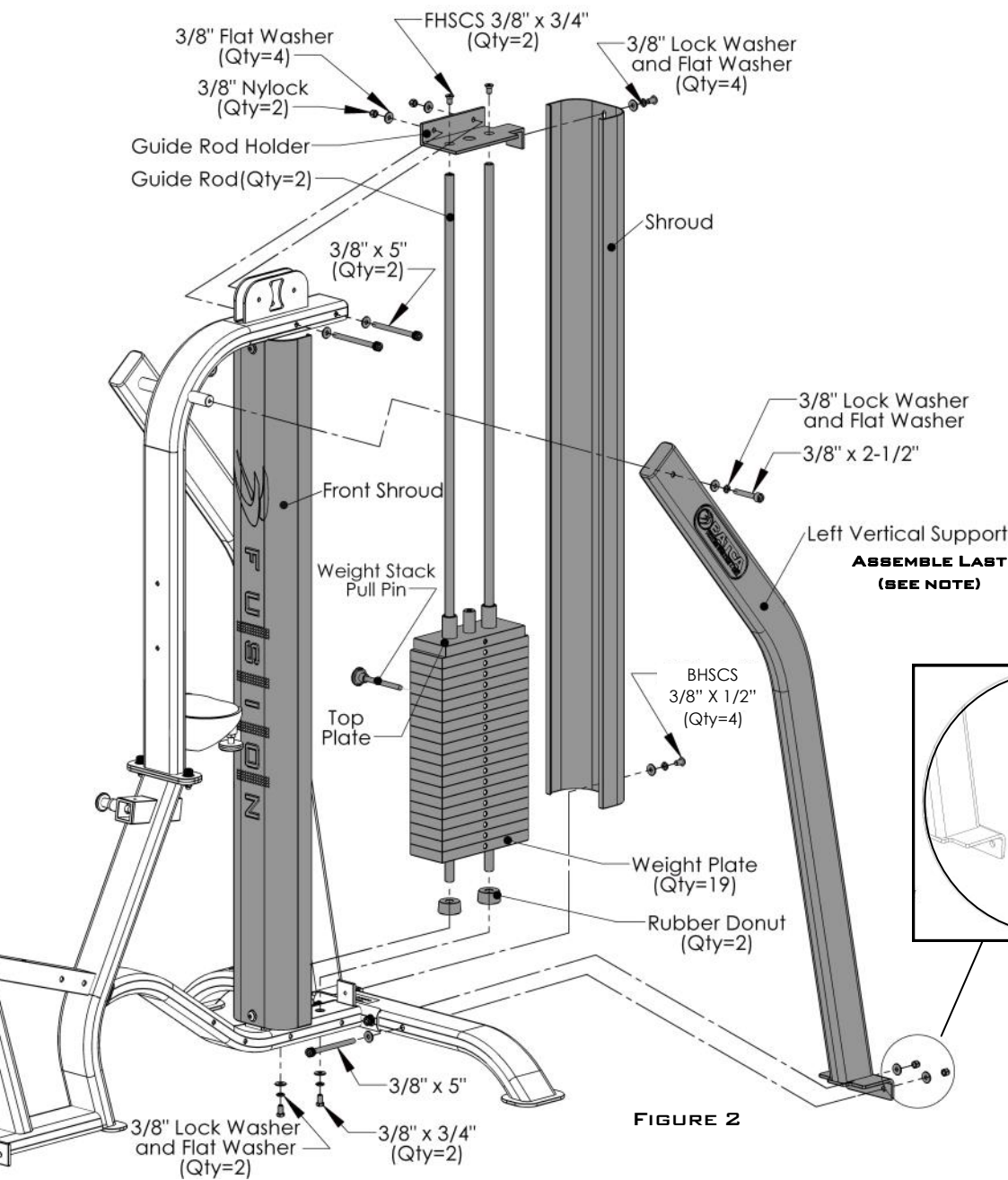

**MAKE SURE ALL
HARDWARE IS
TIGHTENED BEFORE
NEXT STEP.**



THIS 3/8\"/>

FIGURE 2

ITEM #	PART #	DESCRIPTION	QTY	ITEM #	PART #	DESCRIPTION	QTY
1	BFM-10747	LEFT VERTICAL SUPPORT	1	45	BFP-52394	SHCS 3/8"-16 x 2-1/2"	1
6	BFM-51490	GUIDE ROD HOLDER	1	47	BFP-51799	SHCS 3/8"-16 x 5"	3
7	BFM-51082	SHROUD	1	49	BFH-50630	FHSCS 3/8"-16 x 3/4"	2
125	BFM-52410	FRONT SHROUD	1	56	BFP-52401	BHSCS 3/8"-16 x 1/2"	4
8	BFM-51051	GUIDE ROD	2	51	BFH-52340	SHCS 3/8"-16 x 3/4"	2
9	BFM-50256	WEIGHT PLATE	19	73	BFH-50146	3/8" FLAT WASHER	13
10	BFM-50529	RUBBER DONUT	2	74	BFH-50157	3/8" NYLOCK	3
11	BFM-10299	TOP WEIGHT PLATE	1	75	BFH-50147	3/8" LOCK WASHER	7
35	BFM-51173	WEIGHT STACK PIN	1				

ALL FLAT WASHERS AND NYLOCKS ARE 3/8" UNLESS OTHERWISE NOTED.

STEP 3:

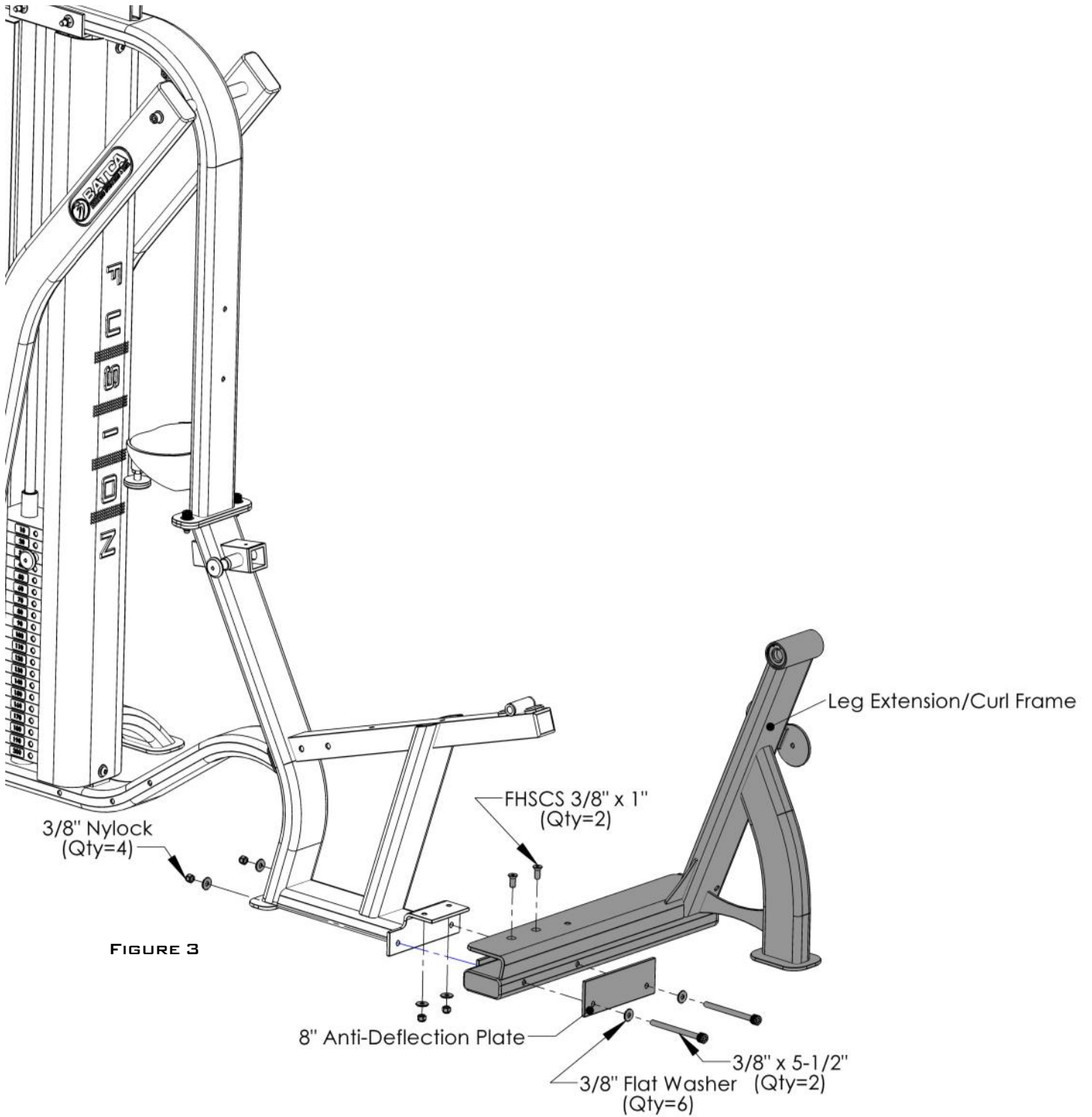

FIGURE 3

ALL FLAT WASHERS AND NYLOCKS ARE 3/8" UNLESS OTHERWISE NOTED.

ITEM #	PART #	DESCRIPTION	QTY
12	BFM-10581	LEG EXTENSION CURL FRAME	1
13	BFM-51143	8" ANTI DEFLECTION PLATE	1
52	BFH-50144	FHSCS 3/8"-16 x 1"	2
53	BFP-52396	SHCS 3/8"-16 x 5 1/2"	2
73	BFH-50146	3/8" FLAT WASHER	6
74	BFH-50157	3/8" NYLOCK	4

STEP 4:

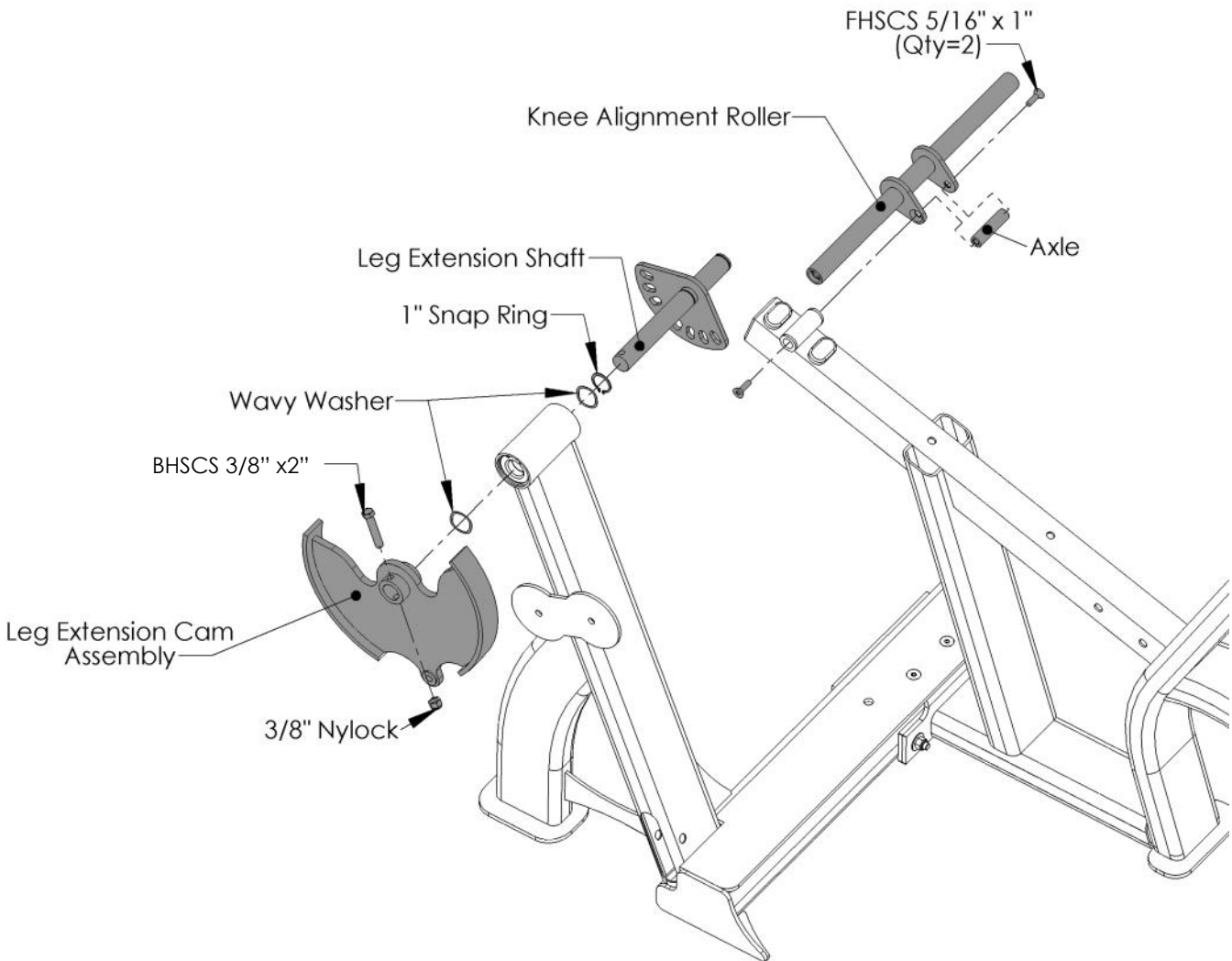

FIGURE 4

ITEM #	PART #	DESCRIPTION	QTY
14	BFM-10141	KNEE ALIGNMENT ROLLER	1
15	BFM-10584	LEG EXTENSION SHAFT	1
16	BFM-10585	LEG EXTENSION CAM ASSEMBLY	1
17	BFM-50222	AXLE	1
54	BFH-50165	1" SNAP RING	1
55	BFH-50337	WAVY WASHER	2
68	BFP-52420	BHSCS 3/8"-16 x 2"	1
57	BFM-50245	FHSCS 5/16" x 1"	2
74	BFH-50157	3/8" NYLOCK	1

ALL FLAT WASHERS AND NYLOCKS ARE 3/8" UNLESS OTHERWISE NOTED.

STEP 5:

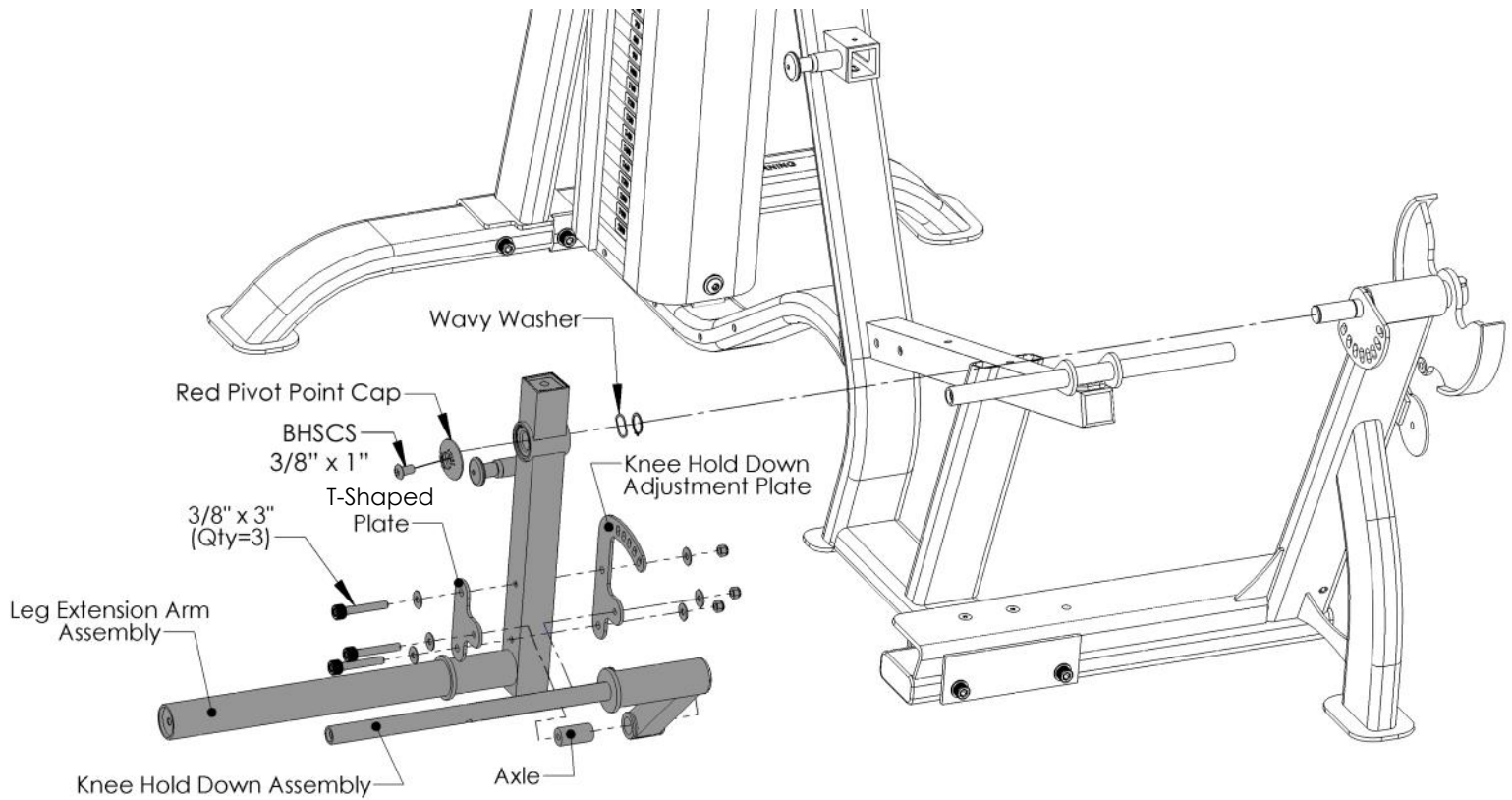

FIGURE 5

ITEM #	PART #	DESCRIPTION	QTY
18	BFM-10742	LEG EXTENSION ARM ASSEMBLY	1
19	BFM-10587	KNEE HOLD DOWN ASSEMBLY	1
20	BFM-51094	AXLE	1
31	BFL-50274	KNEE HOLD DOWN ADJUSTMENT PLATE	1
32	BFL-50211	T-SHAPED PLATE	1
54	BFH-50165	1" SNAP RING	1
55	BFH-50337	WAVY WASHER	1
58	BFP-51747	SHCS 3/8"-16 x 3"	3
73	BFH-50146	3/8" FLAT WASHER	6
74	BFH-50157	3/8" NYLOCK	3
126	BFM-52422	RED PIVOT POINT CAP	1
127	BFH-50620	BHSCS 3/8" x 1"	1

ALL FLAT WASHERS AND NYLOCKS ARE 3/8" UNLESS OTHERWISE NOTED.

STEP 6:

NOTE: EACH CABLE WITH A THREADED BOLT ON EITHER END MUST BE THREADED AT LEAST 1/2" INTO ITS ATTACHMENT.

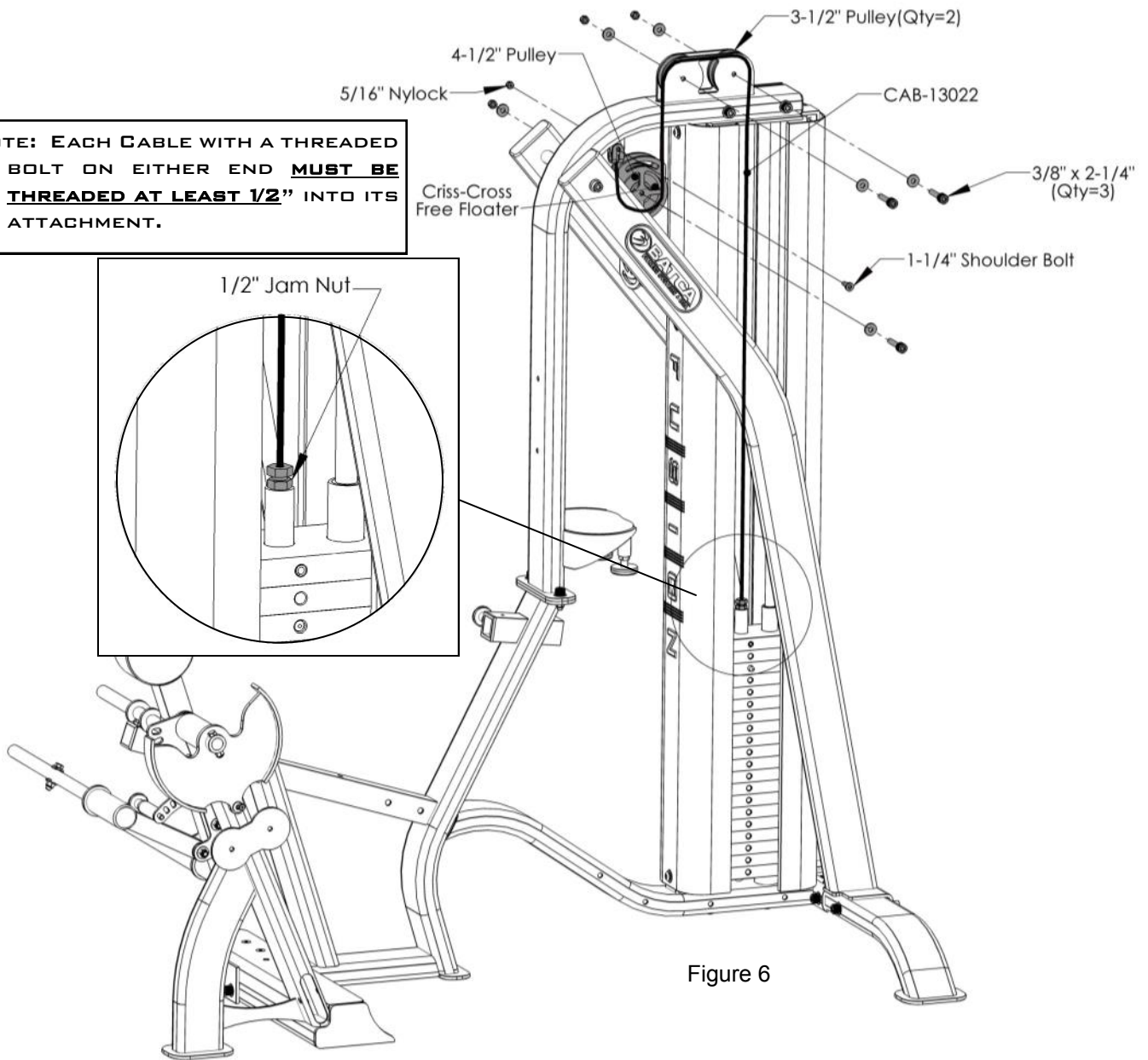
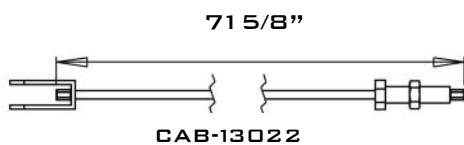

Figure 6



ITEM #	PART #	DESCRIPTION	QTY
21	BFM-10611	CRISS-CROSS FREE FLOATER	1
41	CAB-13022	WEIGHT STACK TO CABLE TIE OUT	1
59	BFH-50174	4 1/2" PULLEY	1
60	BFH-50173	3 1/2" PULLEY	2
61	BFH-50267	5/16" NYLOCK	1
62	BFP-51752	SHCS 3/8"-16 x 2 1/4	3
63	BFH-50250	1-1/4" SHOULDER BOLT	1
73	BFH-50146	3/8" FLAT WASHER	6
74	BFH-50157	3/8" NYLOCK	3

ALL FLAT WASHERS AND NYLOCKS ARE 3/8" UNLESS OTHERWISE NOTED.

STEP 7:

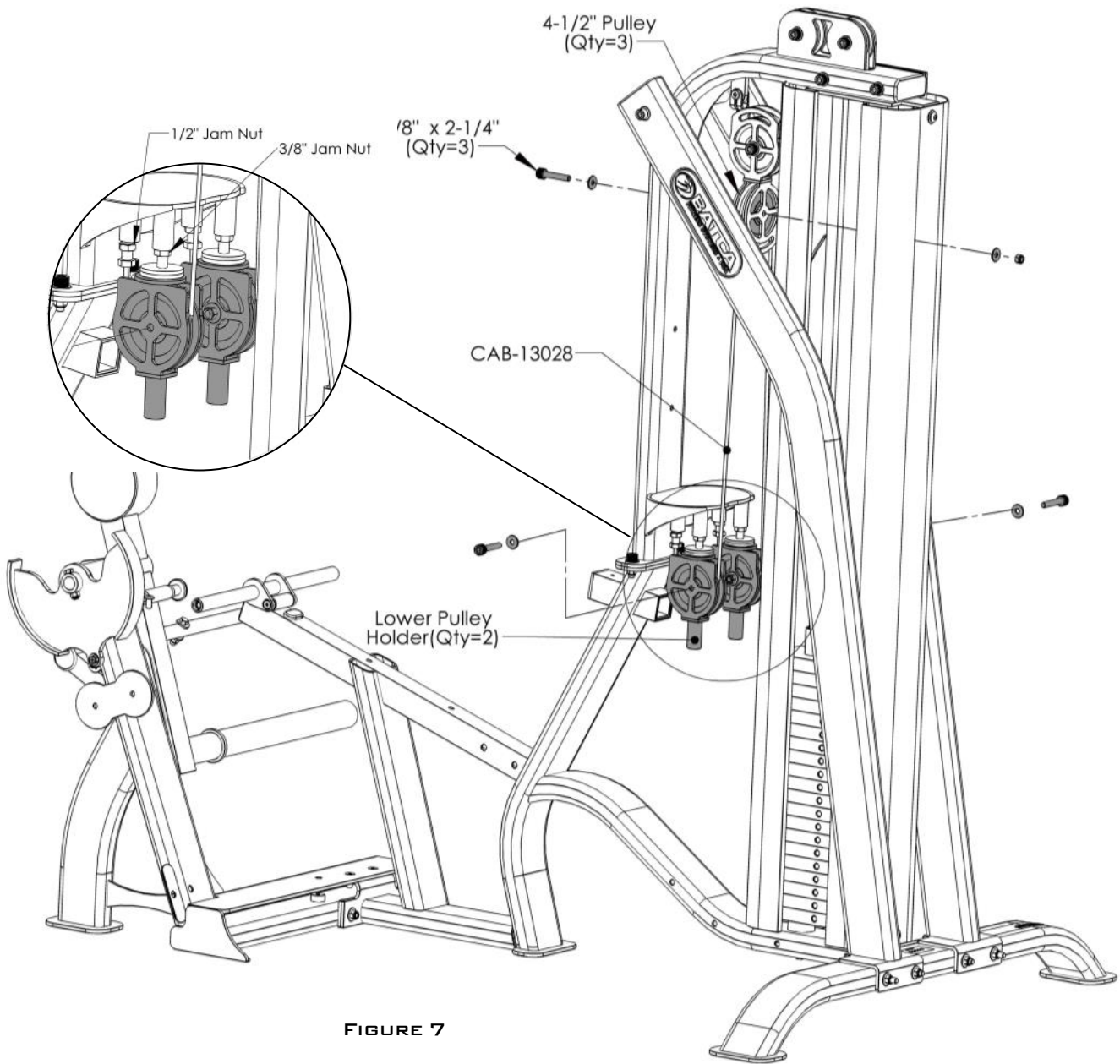
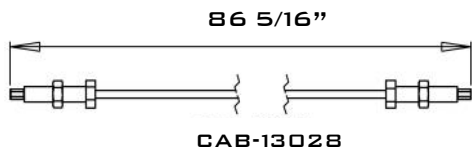

FIGURE 7



ALL FLAT WASHERS AND NYLOCKS ARE 3/8" UNLESS OTHERWISE NOTED.

ITEM #	PART #	DESCRIPTION	QTY
22	BFM-10610	LOWER PULLEY HOLDER	2
42	CAB-13028	FUSION FREE FLOATER CABLE	1
59	BFH-50174	4 1/2" PULLEY	3
62	BFP-51752	SHCS 3/8"-16 x 2 1/4"	3
73	BFH-50146	3/8" FLAT WASHER	6
74	BFH-50157	3/8" NYLOCK	3

STEP 8:



**NOTE: IF LEG PRESS OPTION IS PURCHASED
SKIP THIS STEP AND CONTINUE TO STEP 9.**

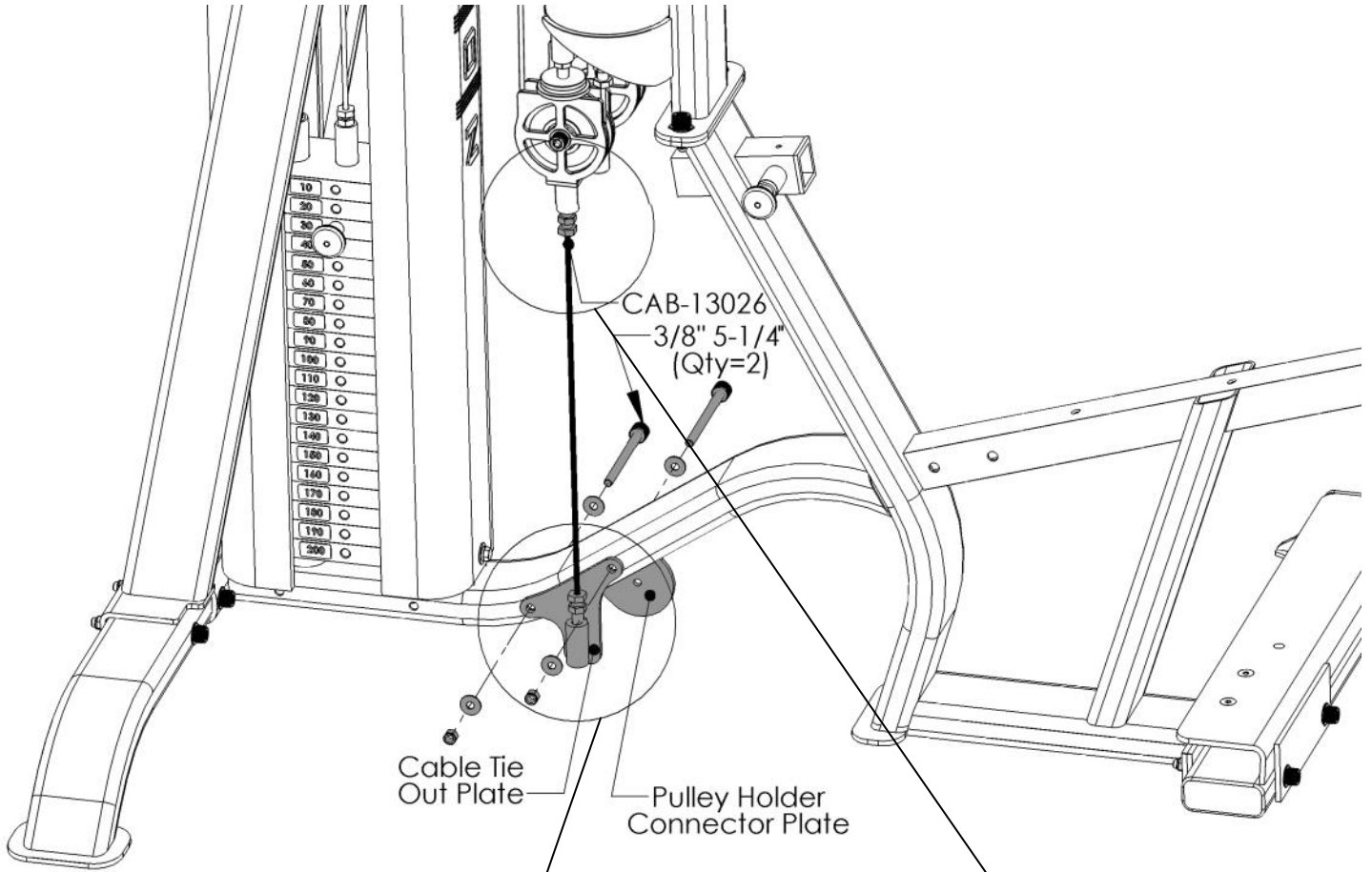
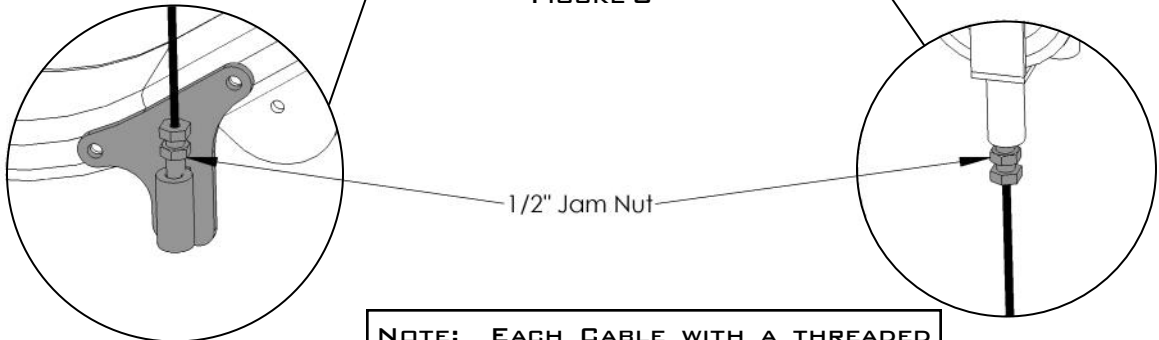
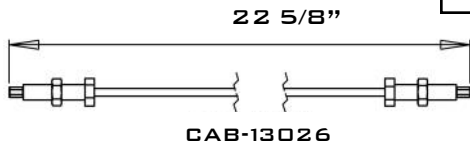

FIGURE 8



NOTE: EACH CABLE WITH A THREADED BOLT ON EITHER END MUST BE THREADED AT LEAST 1/2" INTO ITS ATTACHMENT.



ALL FLAT WASHERS AND NYLOCKS ARE 3/8" UNLESS OTHERWISE NOTED.

ITEM #	PART #	DESCRIPTION	QTY
23	BFM-10612	CABLE TIE OUT PLATE	1
33	BFL-50203	PULLEY HOLDER CONNECTOR PLATE	1
43	CAB-13026	FUSION CABLE TIE OUT	1
48	BFP-51756	SHCS 3/8"-16 x 5 1/4"	2
73	BFH-50146	3/8" FLAT WASHER	4
74	BFH-50157	3/8" NYLOCK	2

STEP 9:

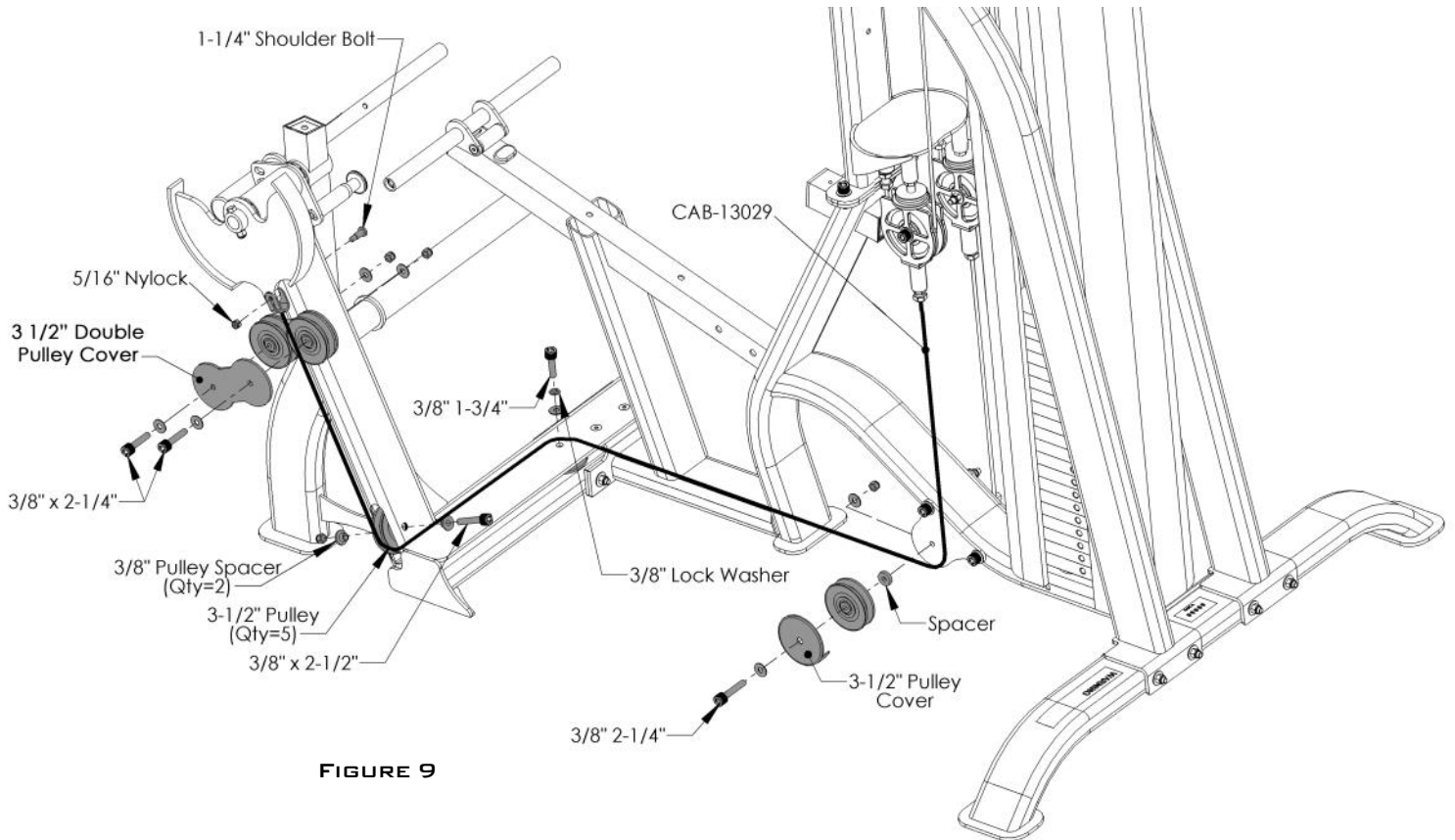
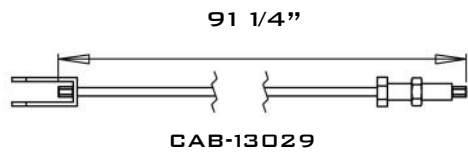

FIGURE 9



ITEM #	PART #	DESCRIPTION	QTY
24	BFM-50505	3 1/2" PULLEY COVER	1
25	BFM-51158	SPACER	1
34	BFL-50221	3 1/2" DOUBLE PULLEY COVER	1
44	CAB-13029	FUSION LEG EXTENSION CABLE	1
45	BFP-	SHCS 3/8"-16 x 2 1/2"	1
60	BFH-50173	3 1/2" PULLEY	5
61	BFM-50267	5/16" NYLOCK	1
62	BFP-51752	SHCS 3/8"-16 x 2 1/4"	3
63	BFH-50250	1 1/4" SHOULDER BOLT	1
64	BFP-52397	SHCS 3/8"-16 x 1 3/4"	1
65	BFH-50605	3/8" PULLEY SPACER	2
73	BFH-50146	3/8" FLAT WASHER	7
74	BFH-50157	3/8" NYLOCK	5
75	BFH-50147	3/8" LOCK WASHER	4

ALL FLAT WASHERS AND NYLOCKS ARE 3/8" UNLESS OTHERWISE NOTED.

STEP 10:

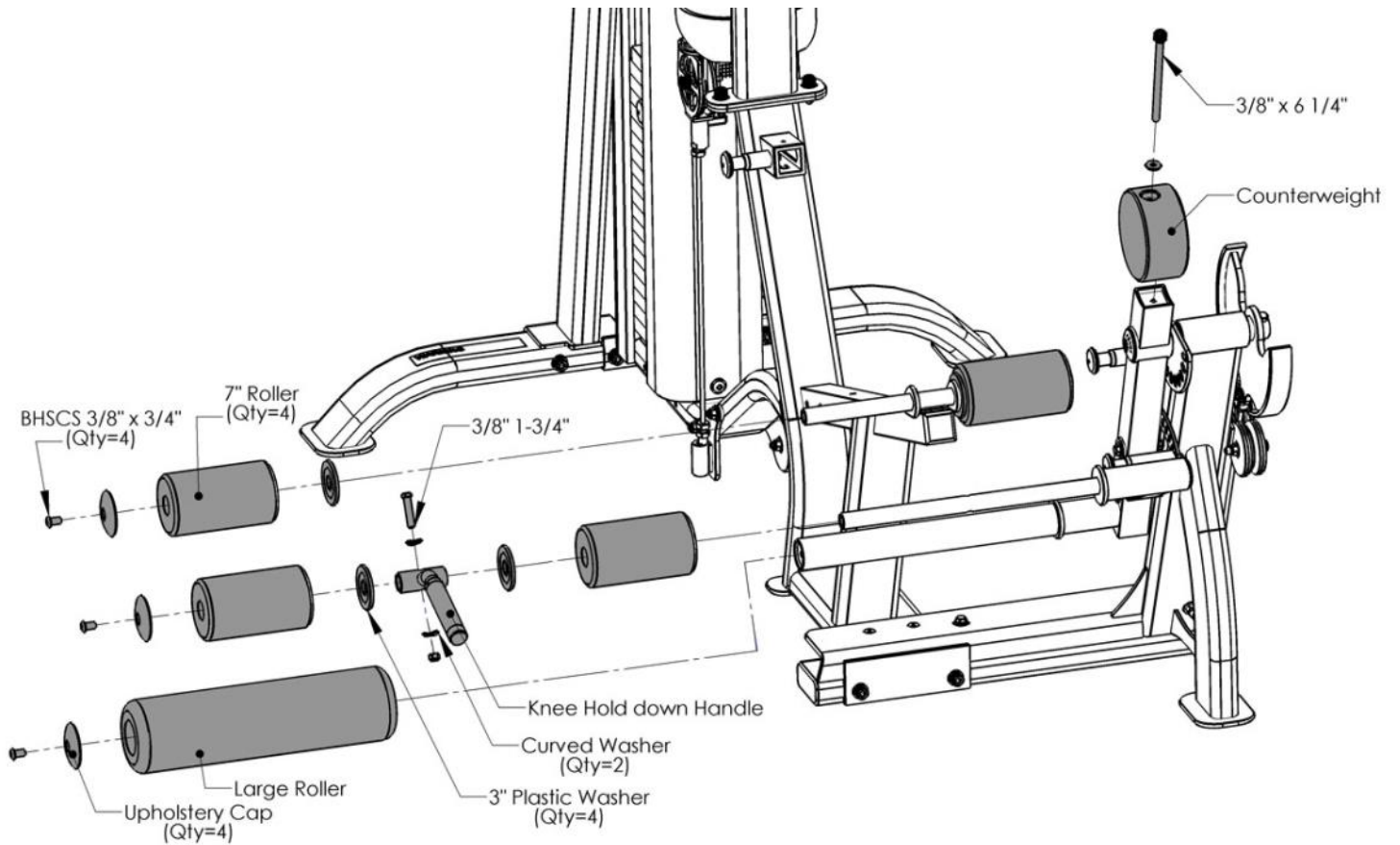

FIGURE 10

ITEM #	PART #	DESCRIPTION	QTY
26	BFM-10588	KNEE HOLD DOWN HANDLE	1
27	BFM-51382	6" COUNTER WEIGHT	1
36	BFU-10121	7" UPHOLSTERY ROLLER	4
39	BFU-10122	LARGE UPHOLSTERY ROLLER	1
64	BFP-52397	SHCS 3/8"-16 x 1-3/4	1
66	BFH-50622	UPHOLSTERY CAP	4
67	BFH-50221	3" PLASTIC WASHER	4
99	BFP-52430	BHSCS 3/8"-16 x 3/4"	4
69	BFH-50204	CURVED WASHER	4
70	BFP-52524	SHCS 3/8"-16 x 6 1/4"	1
73	BFH-50146	3/8" FLAT WASHER	1
74	BFH-50157	3/8" NYLOCK	1
75	BFH-50147	3/8" LOCK WASHER	2

ALL FLAT WASHERS AND NYLOCKS ARE 3/8" UNLESS OTHERWISE NOTED.

STEP 11:

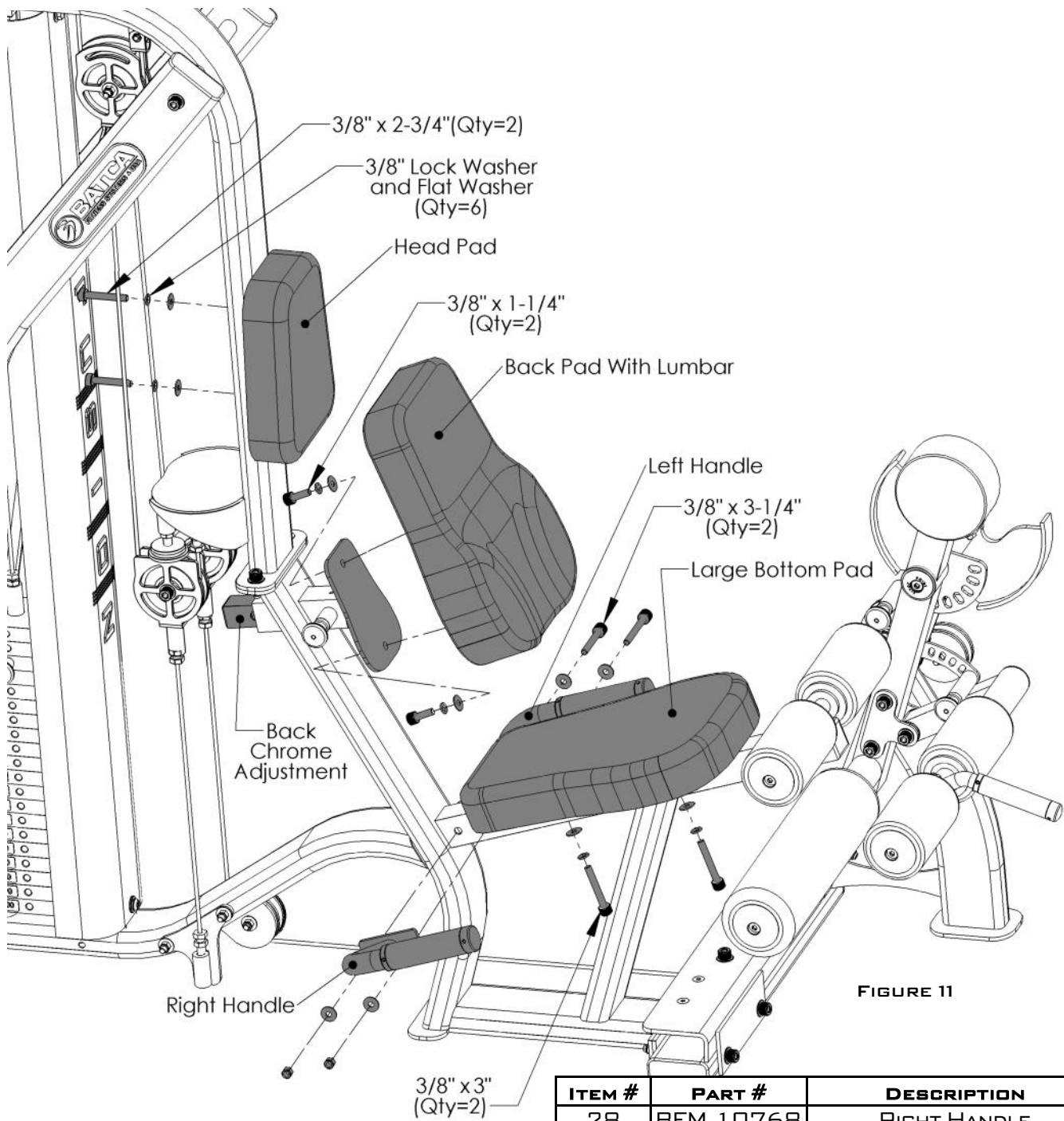

FIGURE 11

ITEM #	PART #	DESCRIPTION	QTY
28	BFM-10768	RIGHT HANDLE	1
29	BFM-10767	LEFT HANDLE	1
30	BFM-10580	BACK CHROME ADJUSTMENT	1
36	BFP-52130	LARGE BOTTOM PAD	1
37	BFP-52137	HEAD PAD	1
38	BFP-52136	BACK PAD WITH LUMBAR	1
46	BFP-51653	SHCS 3/8"-16 X 1 1/4"	2
58	BFP-51747	SHCS 3/8"-16 X 3"	2
71	BFP-51750	SHCS 3/8"-16 X 2 3/4"	2
72	BFP-51748	SHCS 3/8"-16 X 3 1/4"	2
73	BFH-50146	3/8" FLAT WASHER	10
74	BFH-50157	3/8" NYLOCK	2
75	BFH-50147	3/8" LOCK WASHER	6

LEG PRESS OPTION

STEP 12:

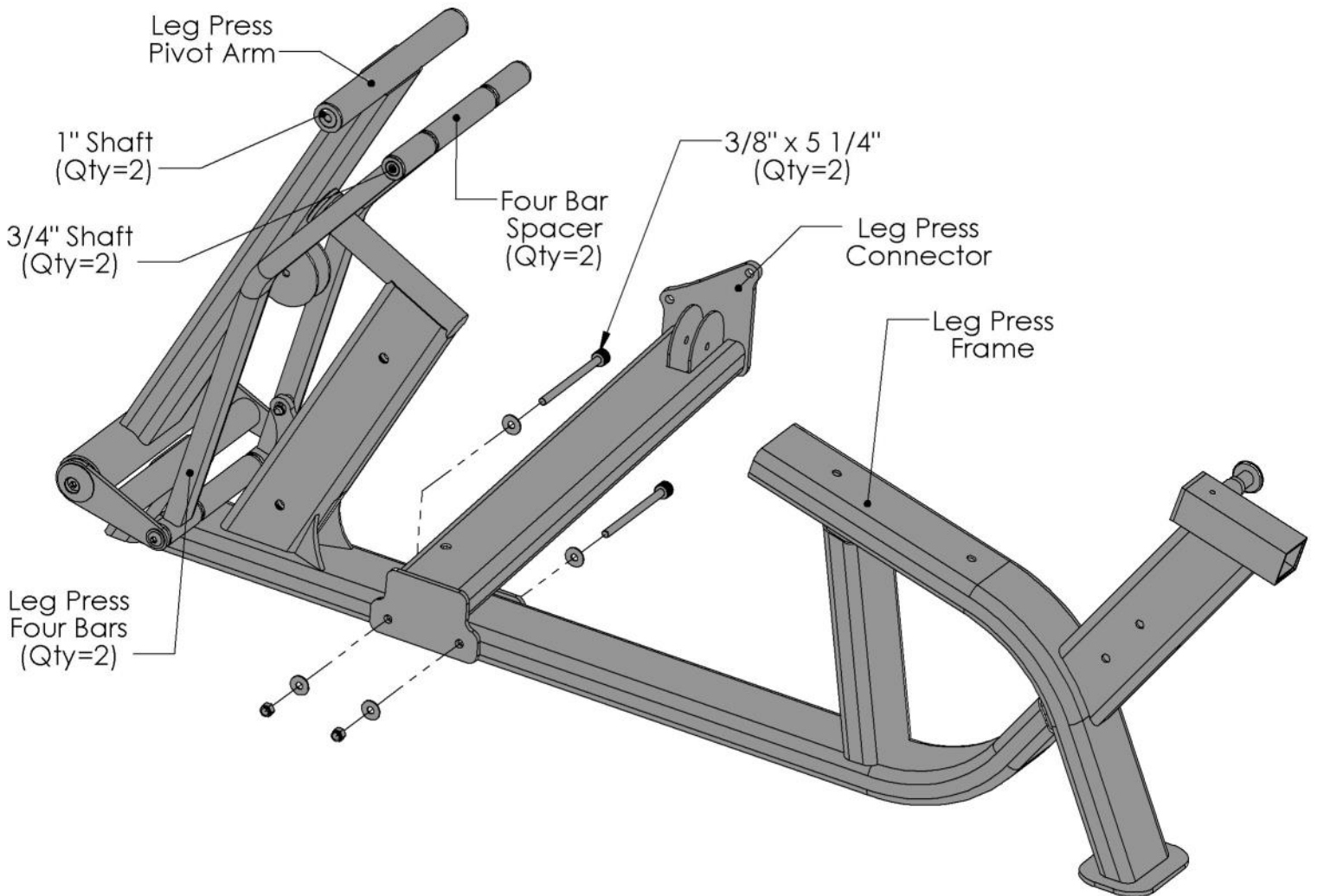

FIGURE 12

ITEM #	PART #	DESCRIPTION	QTY
76	BFM-10575	LEG PRESS CONNECTOR	1
77	BFM-11042	LEG PRESS FRAME	1
78	BFM-11034	FOUR BAR	2
79	BFM-52449	FOUR BAR SPACER	2
80	BFM-11035	LEG PRESS PIVOT ARM	1
81	BFP-51844	1" SHAFT	2
82	BFP-51846	3/4" SHAFT	2
100	BFH-50146	3/8" FLAT WASHER (BLACK)	4
101	BFH-50157	3/8"-16 NYLOCK (BLACK)	2
97	BFP-51756	SHCS 3/8"-16 X 5 1/4" P5	2

ALL FLAT WASHERS AND NYLOCKS ARE 3/8" UNLESS OTHERWISE NOTED.

STEP 13:



NOTE: THIS STEP MAY BE PRE-ASSEMBLED

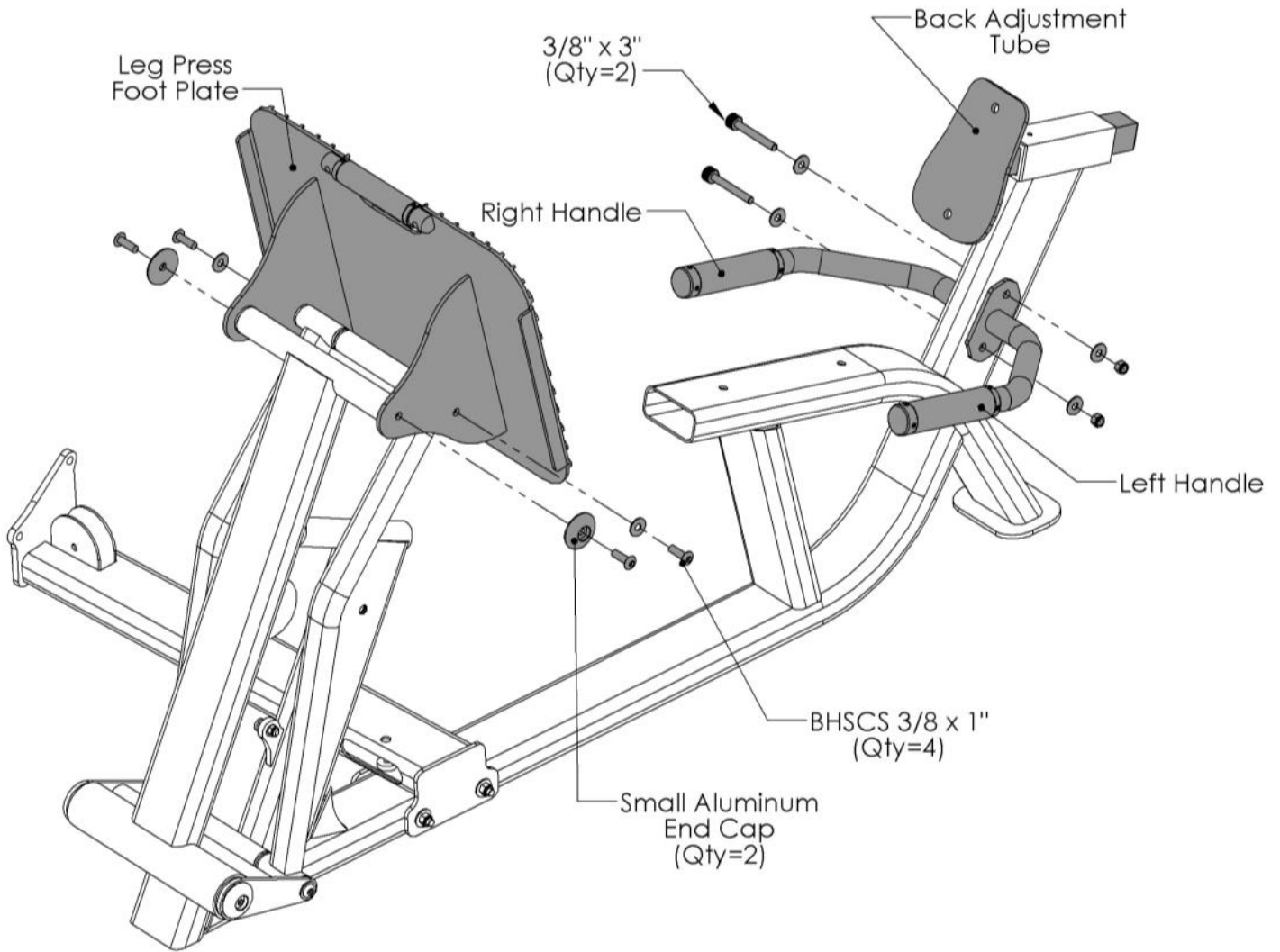

FIGURE 13

ALL FLAT WASHERS AND NYLOCKS ARE 3/8" UNLESS OTHERWISE NOTED.

ITEM #	PART #	DESCRIPTION	QTY
83	BFM-11036	LEG PRESS FOOT PLATE	1
84	BFM-11040	RIGHT HANDLE	1
85	BFM-11041	LEFT HANDLE	1
86	BFM-10106	BACK ADJUSTMENT TUBE	1
87	BFP-51696	SMALL ALUMINUM END CAP	2
90	BFP-51700	BHSCS 3/8" x 1"	4
105	BFP-51747	SHCS 3/8" x 3"	2
100	BFH-50146	3/8" FLAT WASHER (BLACK)	6
101	BFH-50157	3/8"-16 NYLOCK (BLACK)	2

STEP 14:



NOTE: THIS STEP MAY BE PRE-ASSEMBLED

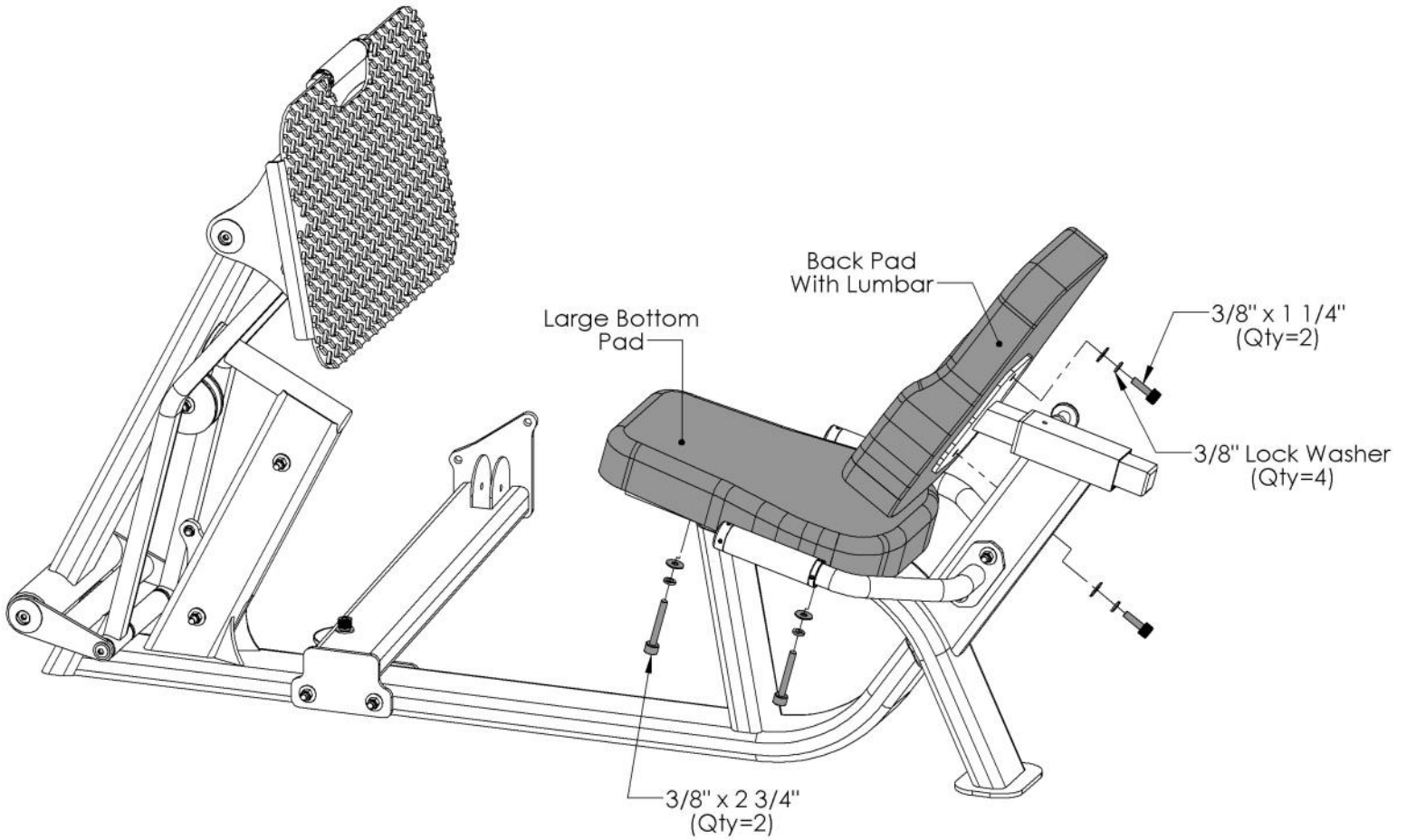

FIGURE 14

ALL FLAT WASHERS AND NYLOCKS ARE 3/8" UNLESS OTHERWISE NOTED.

ITEM #	PART #	DESCRIPTION	QTY
104	BFP-52136	BACK PAD WITH LUMBAR	1
103	BFP-52130	LARGE BOTTOM PAD	1
92	BFP-51653	SHCS 3/8" x 1 1/4"	2
96	BFP-51750	SHCS 3/8" x 2 3/4"	2
99	BFH-50147	3/8" LOCK WASHER	4
100	BFH-50146	3/8" FLAT WASHER (BLACK)	4

Step 15:

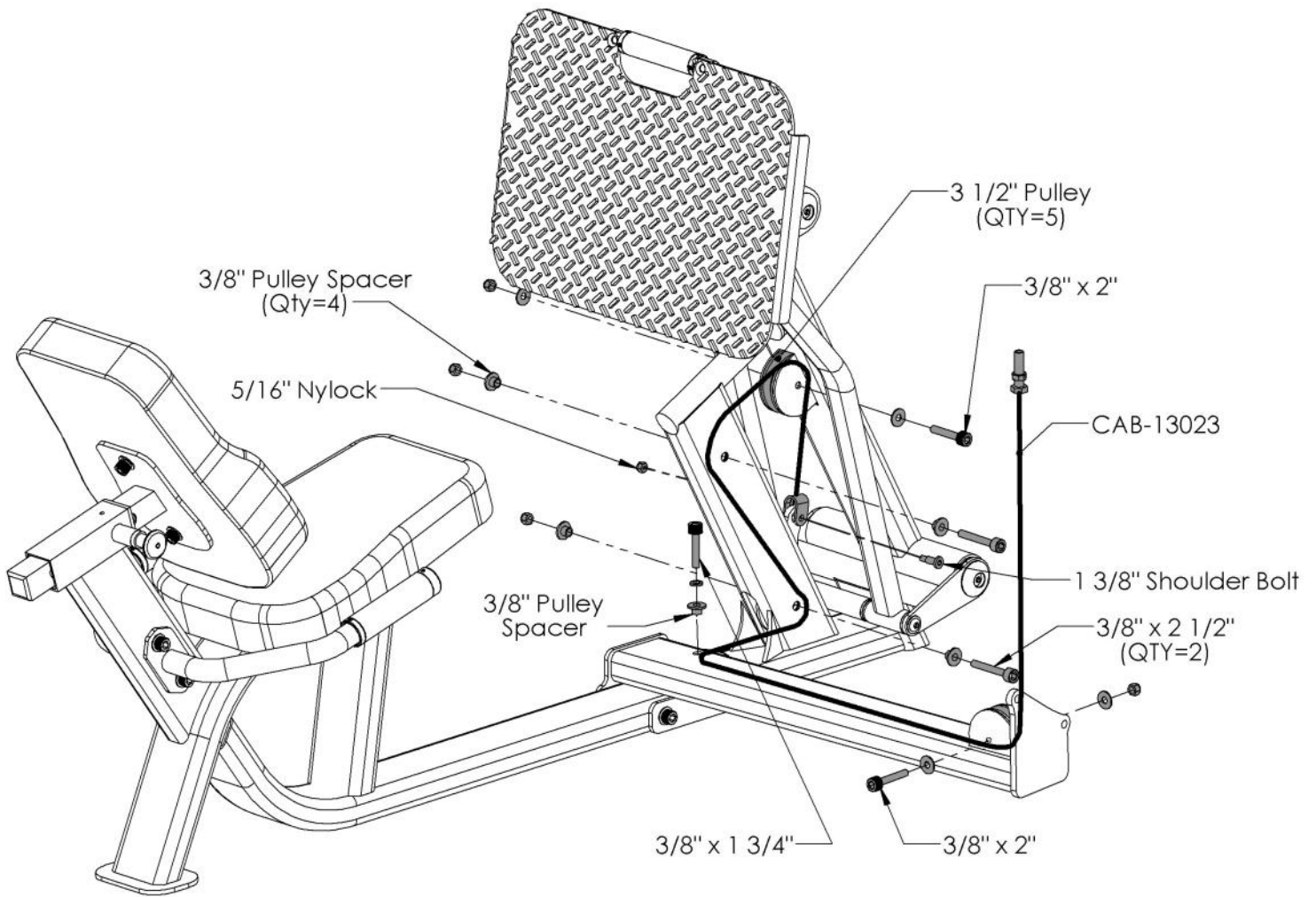
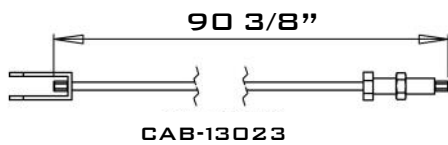

FIGURE 15



ALL FLAT WASHERS AND NYLOCKS ARE 3/8" UNLESS OTHERWISE NOTED.

ITEM #	PART #	DESCRIPTION	QTY
102	CAB-13023	FREE FLOATER TO LEG PRESS	1
88	BFH-50173	3 1/2" PULLEY	5
89	BFH-50605	3/8" PULLEY SPACER	5
93	BFP-52397	SHCS 3/8" x 1 3/4"	1
94	BFP-51759	SHCS 3/8" x 2"	2
95	BFP-52394	SHCS 3/8" x 2 1/2"	2
91	BFP-50351	1 3/8" SHOULDER BOLT	1
98	BFM-50267	5/16 NYLOCK	1
100	BFH-50146	3/8" FLAT WASHER (BLACK)	6
101	BFH-50157	3/8"-16 NYLOCK (BLACK)	4

STEP 16:

FIGURE 16

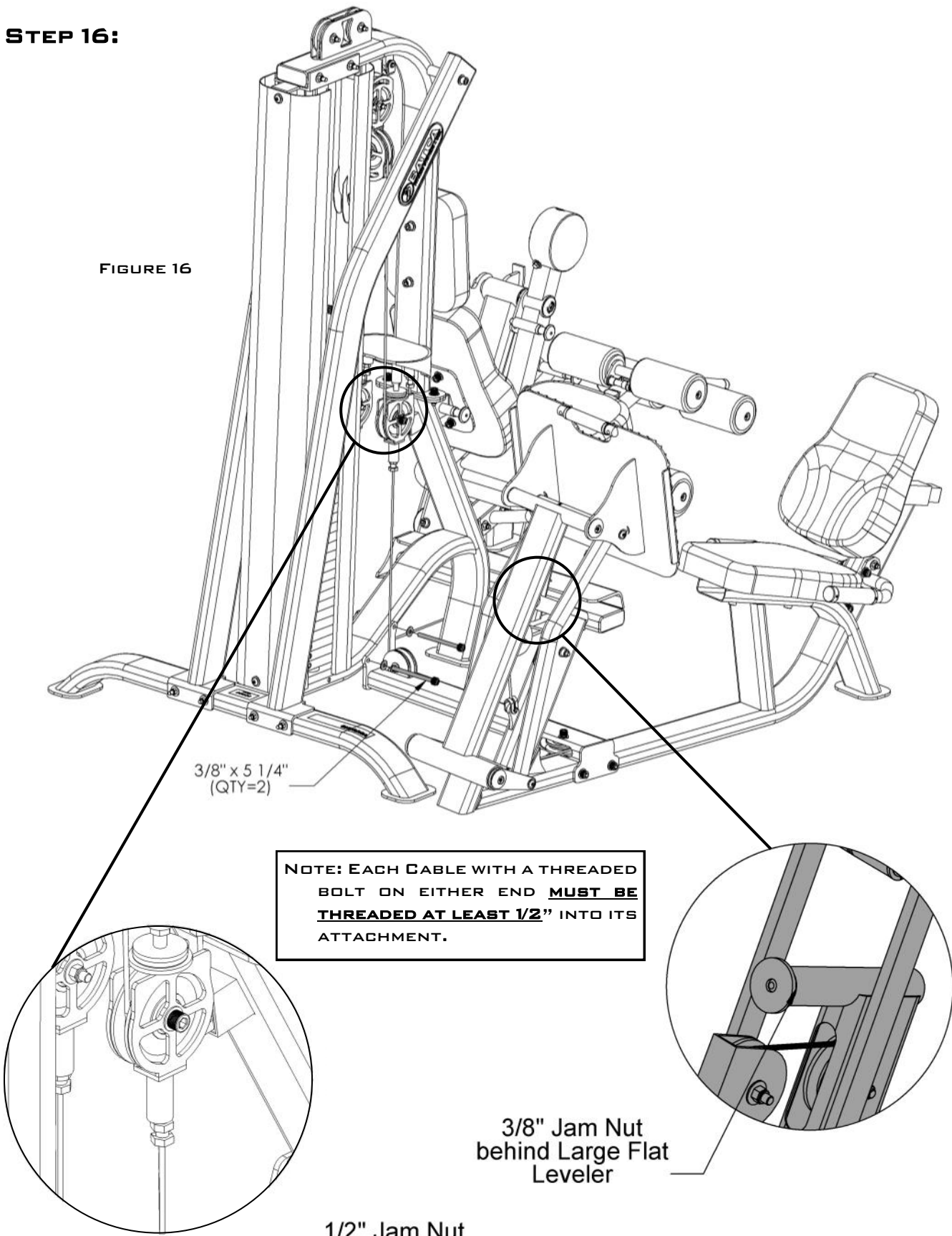

NOTE: EACH CABLE WITH A THREADED BOLT ON EITHER END MUST BE THREADED AT LEAST 1/2" INTO ITS ATTACHMENT.

3/8" Jam Nut behind Large Flat Leveler

1/2" Jam Nut

ALL FLAT WASHERS AND NYLOCKS ARE 3/8" UNLESS OTHERWISE NOTED.

ITEM #	PART #	DESCRIPTION	QTY
97	BFP-51756	SHCS 3/8" x 5 1/4"	2
100	BFH-50146	3/8 FLAT WASHER	4
101	BFH-50157	3/8" NYLOCK	2

STEP 19:

WEIGHT STACK DECALS:

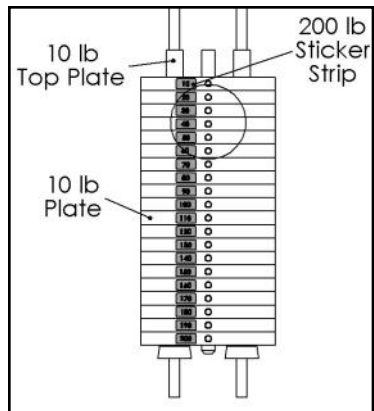

200LB STACK
(STANDARD)

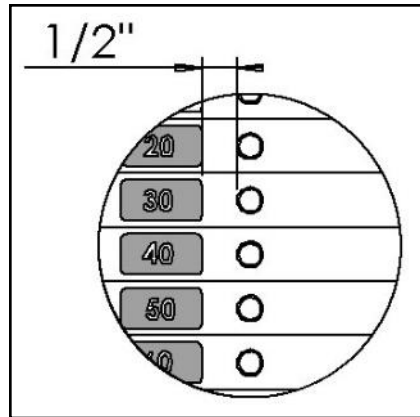

GUIDE ROD LUBRICATION:

- CLEAN GUIDE RODS WITH A LINT-FREE CLOTH AND APPLY A THIN LAYER OF SILICON LUBRICANT (PART # BFH-50262) TO EACH GUIDE ROD. THIS WILL ENSURE A GLASS SMOOTH PERFORMANCE FROM YOUR WEIGHT STACK.

SERIAL NUMBER:

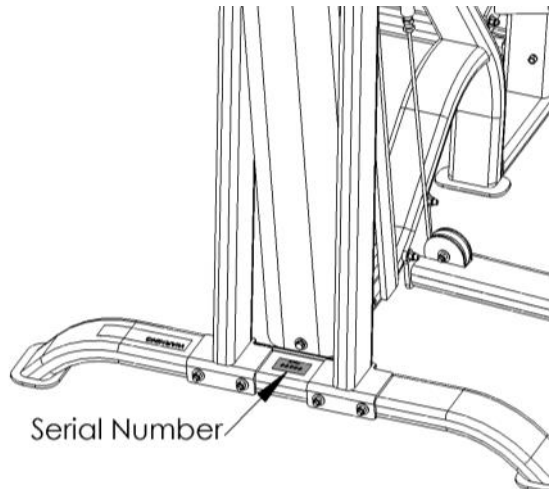

- **RECORD** YOUR SERIAL NUMBER ON THE FRONT OF THIS MANUAL AND KEEP FOR YOUR RECORDS. THE SERIAL NUMBER CAN BE FOUND ON THE BACK OF THE CAGE AS SEEN IN THE FIGURE.

CABLE ADJUSTMENTS

- **ADJUST** CABLES TO PROPER TENSION FROM ANY OF THE LOCATIONS SHOWN BELOW.
- **HOW TO BEGIN:** IN ORDER TO GET THE PROPER TENSION IN YOUR CABLES, IT IS RECOMMENDED THAT YOU FOLLOW THE SEQUENCE 1-5 AS SHOWN ON PAGES 29 AND 30. THE NUMBERS FOR THIS SEQUENCE CAN BE FOUND IN THE UPPER LEFT CORNER OF EACH OF THE DETAILED VIEWS. EACH DETAILED VIEW BELOW WILL REFER YOU TO THE ORIGINAL FIGURE FOR MORE DETAILED INFORMATION. FOLLOW THE DETAILED INFORMATION FOUND IN EACH REFERENCED FIGURE.
- **NOTE:** IF THE TOP PLATE RAISES OFF OF THE SECOND PLATE IN THE WEIGHT STACK, THEN THE CABLE TENSION IS TOO TIGHT. YOU WILL NEED TO TAKE SOME OF THE TENSION OUT TO LOWER THE TOP PLATE FLUSH WITH THE SECOND PLATE.

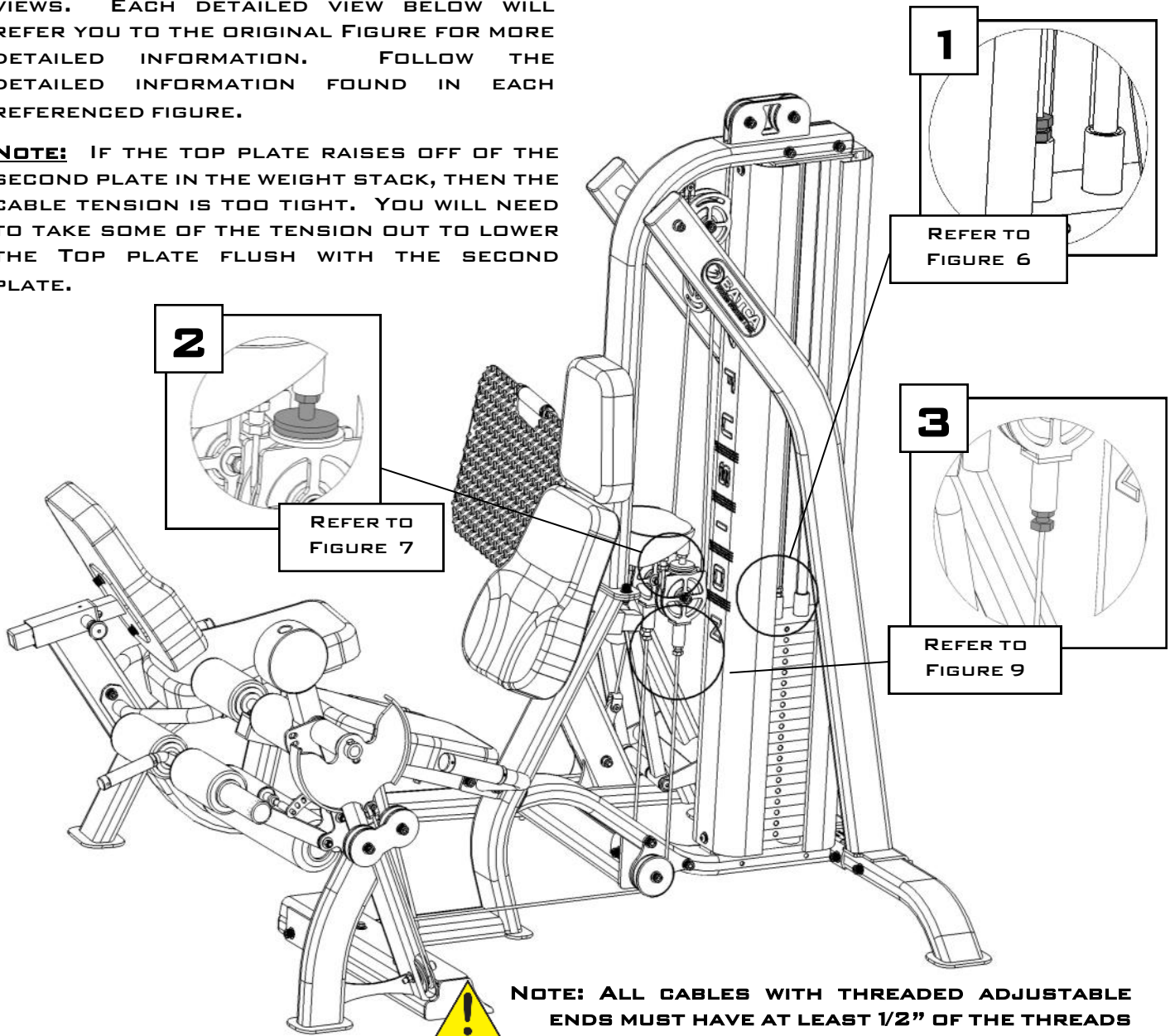

NOTE: ALL CABLES WITH THREADED ADJUSTABLE ENDS MUST HAVE AT LEAST 1/2" OF THE THREADS THREADED INTO ITS COUNTERPART. IT IS VERY IMPORTANT THAT THE 1/2" JAM NUT BE WRENCH TIGHTENED TO THE COUNTERPART TO ENSURE THAT THE THREADED ADJUSTABLE END OF THE CABLE DOES NOT BACK OUT OF ITS COUNTERPART.

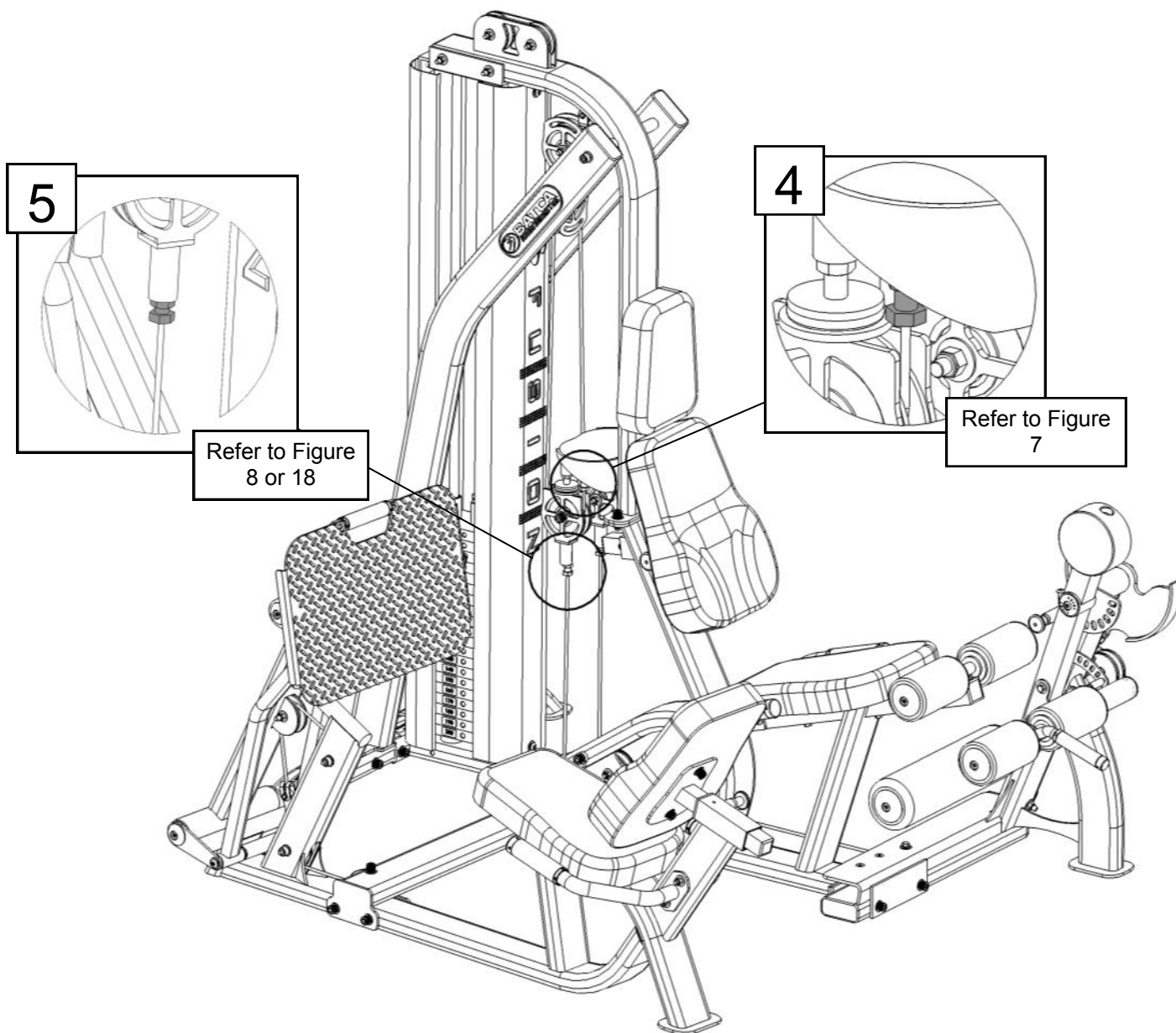

NOTE: ALL LEVELERS SHOULD HAVE AT LEAST 1/2" OF THE THREADS THREADED IN TO ITS COUNTERPART. IT IS VERY IMPORTANT THAT THE 3/8" JAM NUT BE WRENCH TIGHTENED TO THE COUNTERPART TO ENSURE THAT THE LEVELER DOES NOT BACK OUT OF THE COUNTERPART.

CABLE COMPARISON CHART

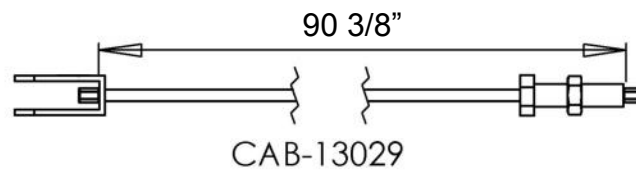
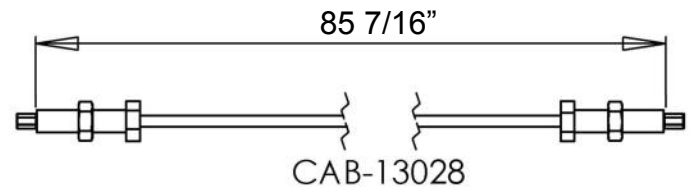
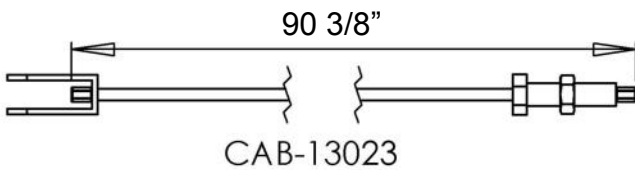
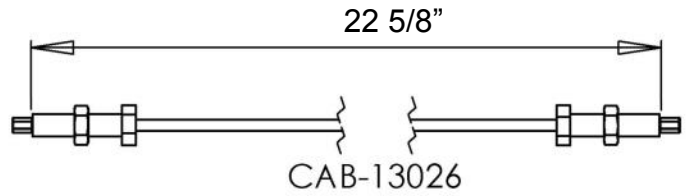
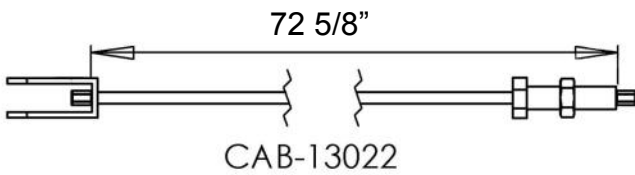

CABLES

ITEM NO.	PART NUMBER	DESCRIPTION	QTY
41	CAB-13022	WEIGHT STACK TO CABLE TIE OUT	1
42	CAB-13028	FUSION FREE FLOATER CABLE	1
43	CAB-13026	FUSION TIE OUT CABLE	1
44	CAB-13029	FUSION LEG EXTENSION CABLE	1
123	CAB-13023	FUSION LEG PRESS CABLE	1



NOTE: CABLES CAB-13022, CAB-13023, AND CAB-13029 HAVE REMOVABLE CABLE STRAP (BFH- 50227) ENDS TO MAKE CABLE ROUTING EASIER. THE CABLE STRAP ENDS CAN BE FOUND PACKAGED WITH THE HARDWARE.

FINAL ASSEMBLY AND TROUBLESHOOTING

IMPORTANT - CHECK THESE COMPONENTS BEFORE USING GYM:

- **POSITION** THE CABLE GUARD TAB ON THE PULLEY COVER SO THAT THE TAB PREVENTS THE CABLE FROM COMING OUT OF ITS TRACK ON THE 3 1/2" PULLEY. AN EXAMPLE OF THIS POSITIONING CAN BE SEEN IN THE FIGURE TO THE RIGHT. THE CABLE GUARD TAB SHOULD BE POSITIONED SO THAT IT IS IN THE MIDDLE OF THE CABLE WRAP ON THE 3 1/2" PULLEY, BETWEEN POINTS "A" AND "B". THIS WILL ALLOW BETTER PROTECTION AND PREVENT THE CABLE FROM RUBBING THE CABLE GUARD TAB. REFER TO STEP 19.

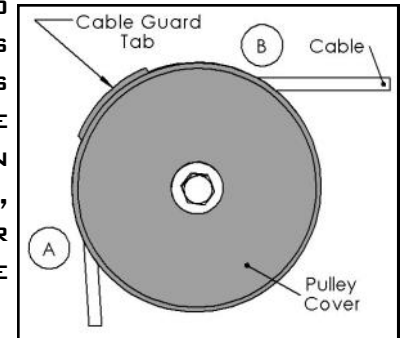

PULLEY COVER
BFM-50345

- EACH CABLE WITH A THREADED BOLT ON EITHER END **MUST BE THREADED AT LEAST 1/2"** INTO ITS ATTACHMENT, WHETHER IT BE A FREE FLOATER, LOCKOUT FREE FLOATER, OR THE TOP PLATE OF THE WEIGHT STACK. EACH MUST ALSO BE SECURED WITH A 1/2" JAM NUT TO ENSURE A SAFE AND PROPER CONNECTION. REFER TO STEPS 6, AND 7. SEE FIGURES BELOW.

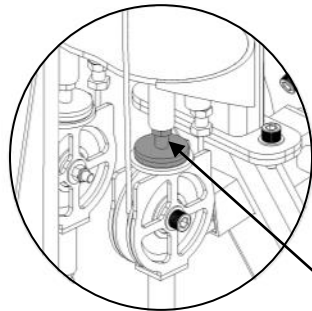

FREE FLOATER W/ LOCKOUT

1/2" JAM NUT

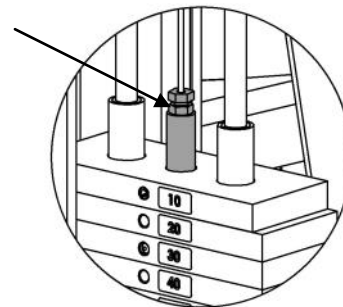

TOP PLATE

PREVENTIVE MAINTENANCE

BATCA FITNESS SYSTEMS STRIVES TO GIVE YOU THE VERY BEST IN QUALITY, PERFORMANCE AND SAFETY THROUGH CAREFULLY ENGINEERED DESIGNS AND EXCELLENT WORKMANSHIP. IN ORDER TO MAINTAIN THIS HIGH LEVEL OF QUALITY THE PREVENTATIVE MAINTENANCE SCHEDULE BELOW SHOULD BE FOLLOWED.

CLEAN UPHOLSTERY, GRIPS, AND ROLLER PADS WITH MILD SOAP AND WATER GENERALLY AFTER EVERY USE. THE GUIDE RODS, CHROME SLIDES AND FRAME SHOULD BE CLEANED WITH A COTTON CLOTH. UPON CLEANING THE GUIDE RODS, A THIN LAYER OF SILICONE OR TEFLON GEL SHOULD BE APPLIED TO EACH ROD TO ENSURE A GLASS SMOOTH PERFORMANCE.

AN OVERALL INSPECTION SHOULD BE DONE BEFORE EACH WORKOUT. IF THE WARNING AND SAFETY DECALS ARE WORN OR HAVE BEEN REMOVED THEY SHOULD BE REPLACED IMMEDIATELY. THE CABLES AND CABLE SYSTEMS SHOULD BE INSPECTED FOR SIGNS OF WEAR AND PROPER TENSION. IN ORDER TO CHECK CABLES PROPERLY YOU SHOULD CAREFULLY RUN THE CABLE THROUGH YOUR FINGERTIPS, CHECKING FOR SIGNS OF WEAR, CRACKS, BURS AND THINNING SPOTS. REPLACE ANY PART AT FIRST SIGNS OF WEAR. CABLES SHOULD BE ADJUSTED FOR PROPER TENSION. SEE ASSEMBLY INSTRUCTIONS FOR THIS DETAIL. ALL HARDWARE, STOPS, AND ADJUSTMENTS SHOULD BE CHECKED AND TIGHTENED AS REQUIRED.

THE GUIDE RODS ON YOUR MACHINE SHOULD BE CLEANED AND LUBRICATED REGULARLY. THIS WILL ENSURE A GLASS SMOOTH PERFORMANCE FROM YOUR WEIGHT STACK. A THIN LAYER OF EITHER SILICONE OR TEFLON GEL SHOULD APPLIED TO EACH ROD.

ALTHOUGH CABLES SHOULD BE INSPECTED DAILY, IT IS IMPORTANT THAT ALL CABLES BE REPLACED AS DIRECTED IN THE SCHEDULE BELOW. PLEASE NOTE THAT AT ANY FIRST SIGN OF WEAR THE CABLE SHOULD BE REPLACED IMMEDIATELY.

IF THERE ARE ANY QUESTIONS CONCERNING MAINTENANCE, PLEASE CONTACT YOUR LOCAL BATCA DEALER OR CONTACT BATCA FITNESS SYSTEMS DIRECTLY AT:

BATCA FITNESS SYSTEMS
(919) 255-1233
WWW.BATCAFITNESS.COM

	DAILY	WEEKLY	MONTHLY	QUARTERLY	YEARS
CLEAN					
UPHOLSTERY		X			
HAND GRIPS		X			
ROLLER PADS		X			
GUIDE RODS			X		
CHROME SLIDES			X		
FRAME			X		
INSPECT					
OVERALL	X				
SAFETY DECALS	X				
CABLES	X				
CABLE TENSION			X		
PULLEYS	X				
HARDWARE	X				
STOPS	X				
UPHOLSTERY	X				
HAND GRIPS			X		
FRAME			X		
BUSHINGS		X			
BEARINGS		X			
LUBRICATE					
GUIDE RODS			X		
REPLACE					
CABLES					3

LIMITED LIFETIME WARRANTY

WHAT IS COVERED

FOR RESIDENTIAL USE:

BATCA FITNESS SYSTEMS WARRANTS ALL OF ITS PRODUCTS AGAINST DEFECTS IN MANUFACTURING, MATERIALS AND WORKMANSHIP UNDER NORMAL USE AND SERVICE FOR ONE YEAR FROM DATE OF PURCHASE INCLUDING PAINT, CHROME, UPHOLSTERY AND GRIPS. BATCA FITNESS SYSTEMS ALSO WARRANTS ALL CABLES, BELTS, BOLTS, NUTS, CAPS, PLUGS, BUMPERS, WASHERS, LEVELERS, DECALS, GAS SPRINGS AND OTHER HARDWARE FOR THREE YEARS AFTER DATE OF PURCHASE; ALL MOVING PARTS, INCLUDING PULLEYS, BUSHINGS, BEARINGS AND PULL PINS FOR FIVE YEARS AFTER DATE OF PURCHASE AND WARRANTS THE FRAME AND ALL WELDED PARTS FOR THE LIFETIME OF THE ORIGINAL PURCHASER.

WHAT IS NOT COVERED

THIS WARRANTY DOES NOT COVER DAMAGE, WHICH RESULTS FROM SHIPPING, MISUSE, ABUSE, NEGLIGENCE, CARELESSNESS, MODIFICATION OR ALTERATION, ACCIDENT, FIRE, FLOOD, "ACTS OF GOD" OR OTHER CONTINGENCIES BEYOND THE CONTROL OF BATCA FITNESS SYSTEMS. THIS WARRANTY ALSO DOES NOT COVER DETERIORATION FROM WEAR AND TEAR OR EXPOSURE OR ANY DEFECT, WHICH WOULD NOT HAVE HAPPENED IF INSTRUCTIONS IN THE OWNER'S MANUAL HAD BEEN FOLLOWED. IMPROPER INSTALLATION, IMPROPER ASSEMBLY OR FOLLOW-UP MAINTENANCE ALONG WITH INSTALLATION OF PARTS OR ACCESSORIES NOT ORIGINALLY INTENDED FOR PRODUCTS OF BATCA FITNESS SYSTEMS ARE ALSO NOT COVERED BY THIS WARRANTY. ONLY GENUINE BATCA PARTS SHOULD BE USED FOR REPLACEMENT, REPAIR, AND MAINTENANCE FOR THIS WARRANTY TO APPLY.

DEFECTIVE PARTS WILL BE REPAIRED OR REPLACED AT BATCA FITNESS SYSTEMS OPTION, WITHOUT PARTS CHARGE TO THE PURCHASER. ALL RETURNS REQUIRE A RETURN AUTHORIZATION PRIOR TO ACCEPTANCE OF REPAIR WORK. BATCA FITNESS SYSTEMS RESERVES THE RIGHT TO MAKE DESIGN CHANGES WITHOUT ANY PRIOR NOTIFICATION AND SHALL NOT BE RESPONSIBLE FOR INCIDENTAL OR CONSEQUENTIAL DAMAGES.

THE PURCHASER IS RESPONSIBLE FOR SHIPPING THE DEFECTIVE PART BACK TO THE FACTORY. REPAIR OR REPLACEMENT IS THE EXCLUSIVE AND SOLE REMEDY OF THE PURCHASER. LABOR CHARGES ASSOCIATED WITH PARTS CHANGEDOVERS ARE NOT COVERED BY THIS WARRANTY. PROOF OF PURCHASE, SERIAL NUMBER, MODEL NUMBER AND DATE OF PURCHASE WILL BE REQUIRED ALONG WITH ALL PERTINENT INFORMATION OF THE ALLEGED DAMAGE.

THIS WARRANTY APPLIES ONLY TO THE ORIGINAL PURCHASER AND IS NOT TRANSFERABLE. CLAIMS UNDER THIS WARRANTY MUST BE MADE DIRECTLY TO BATCA FITNESS SYSTEMS.

BATCA FITNESS SYSTEMS
1207 N. NEW HOPE ROAD
RALEIGH, NC 27610
(919) 255-1233

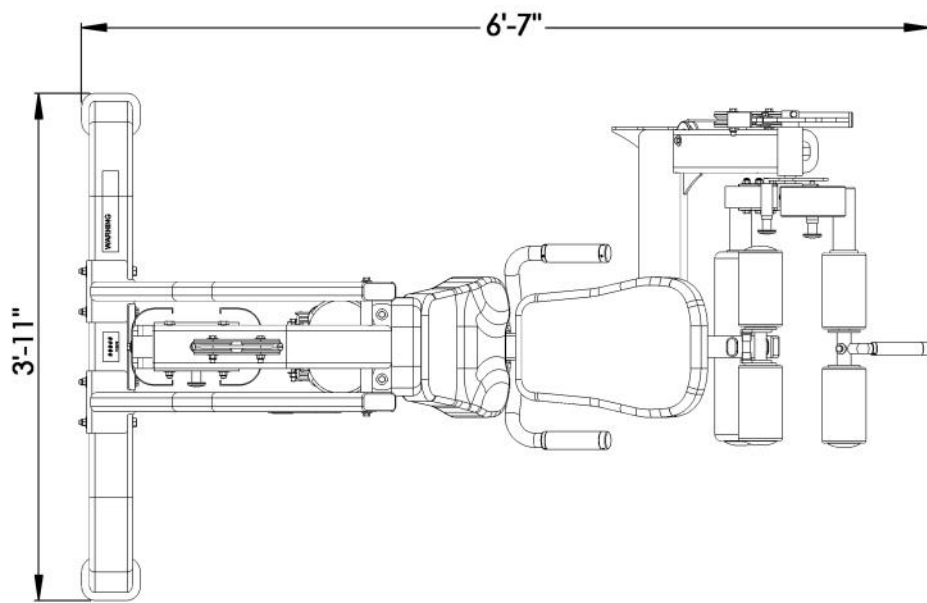
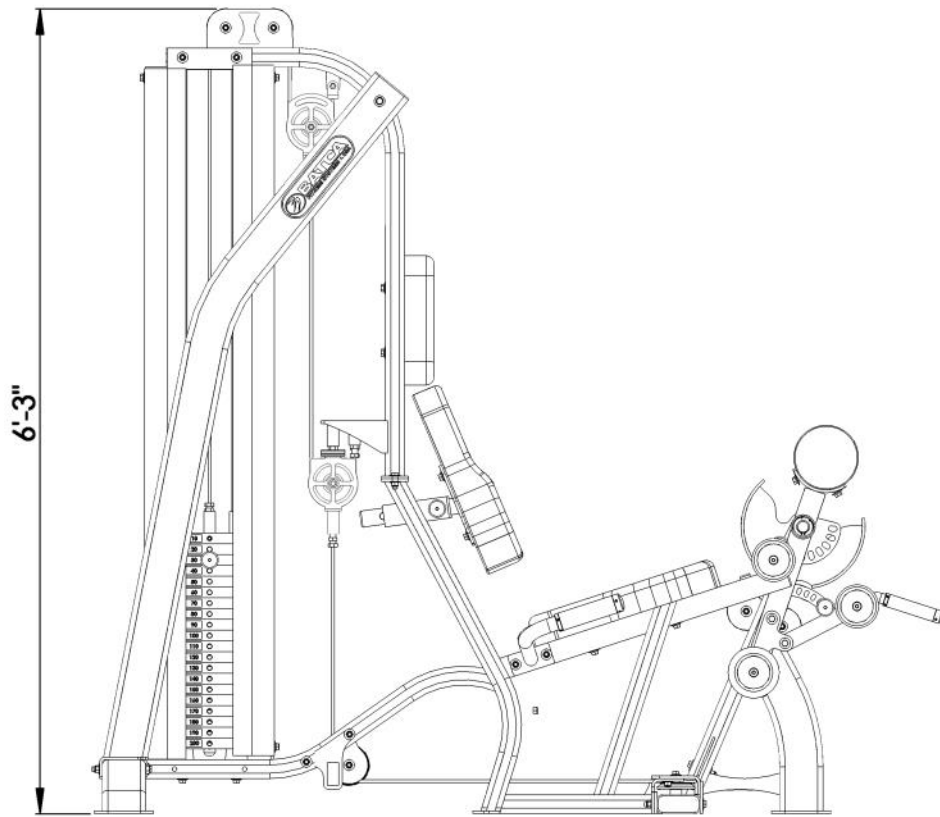

LAYOUT DIAGRAM WITHOUT LEG PRESS

THE FUSION WITHOUT LEG PRESS HAS A LAYOUT DIMENSION OF 3'-11" (WIDTH) X 6' X 7" (LENGTH) X 6'-3" (HEIGHT). THERE SHOULD BE A MINIMUM OF 18", PREFERABLY 24", OF WORKING SPACE AROUND THE ENTIRE UNIT.

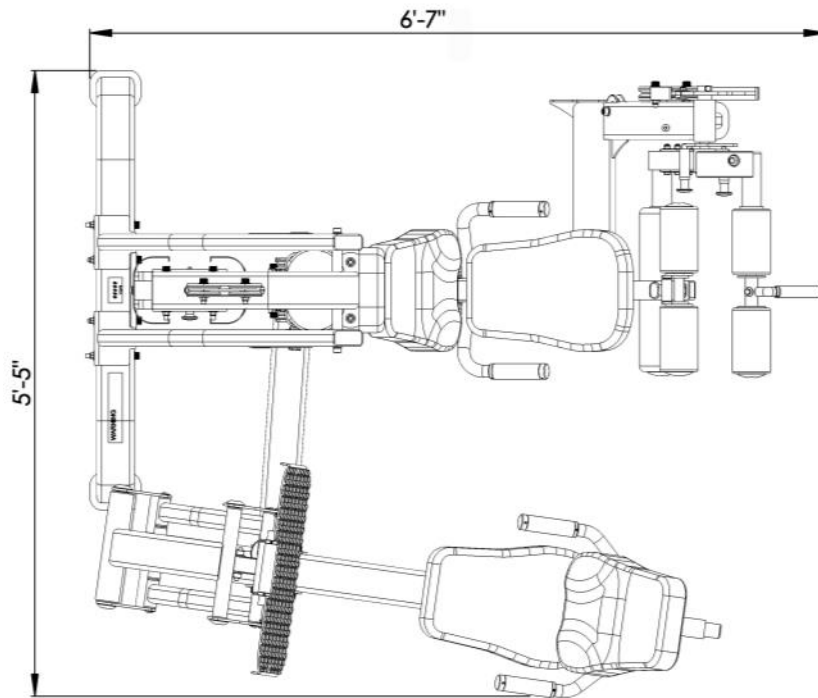
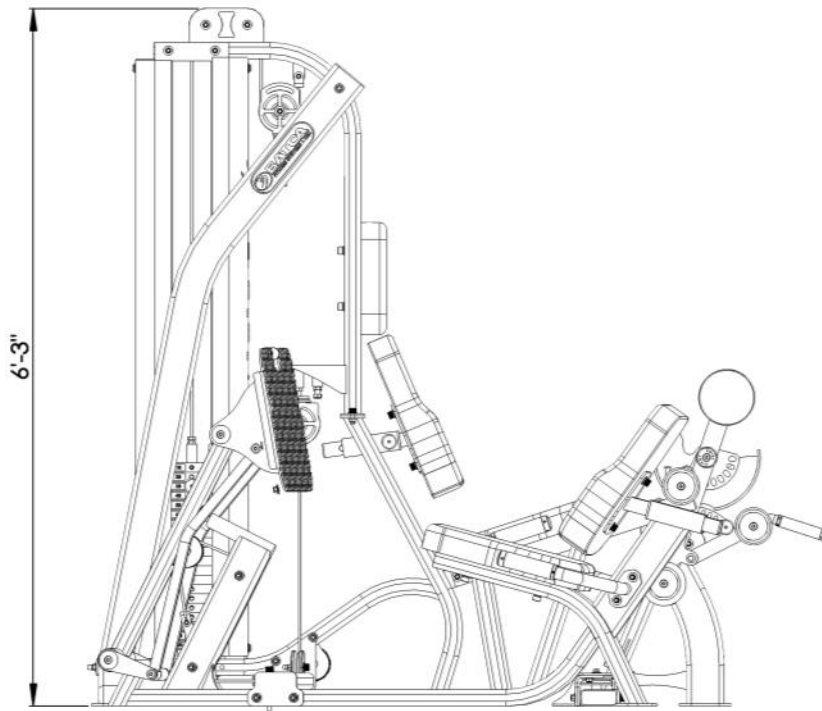

LAYOUT DIAGRAM WITH LEG PRESS

THE FUSION WITH LEG PRESS HAS A LAYOUT DIMENSION OF 5'-5" (WIDTH) X 6'-7" (LENGTH) X 6'-3" (HEIGHT). THERE SHOULD BE A MINIMUM OF 18", PREFERABLY 24", OF WORKING SPACE AROUND THE ENTIRE UNIT.