

AXIS

Revision 0

June 2018

Freeweight Rack Owner's Manual



Serial Number Here

Date of Purchase



BATCA
fitness systems · usa

Instructions

Congratulations on the purchase of your new Batca AXIS Freeweight Rack. This gym will provide you with a lifetime of enjoyment to meet your strength training needs. Batca Fitness Systems strives to build the best quality gyms and to package these gyms in such a way to avoid any damage during shipping.

In order to get started with your assembly you should first familiarize yourself with this manual. It is recommended that you read through each step thoroughly before you begin. Begin by opening your boxes and separating all of your parts. Verify that all parts are accounted for and have no damage. When all parts are accounted for, you may begin your assembly. Some items may have been pre-assembled for your convenience. Please note that hardware quantities shown reflect total quantities for your gym and may not reflect actual quantities in each bag. Assemble your gym on a solid level surface. This will ensure the best possible performance, function, and safety for the gym and your workout.

Assemble your gym according to the step by step instructions found in this manual. Failure to do so will void your warranty and may result in personal injury. After assembly, you should check each station to ensure correct operation. If a problem arises, recheck your assembly with these instructions to verify correct assembly. If you are unable to correct a problem or have questions with your assembly please contact your authorized Batca dealer.

Warning

Batca Fitness Systems has built this gym to give you a safe, effective and enjoyable workout. However, there is a risk assumed by individuals who use this type of equipment. It is very important that all warnings and instructions are read and followed before beginning any exercise program.

It is also very important to read and follow the preventative maintenance schedule described in this manual. If any of the warning labels or stickers are worn, faded, torn, scratched or missing they should be replaced immediately.

WARNING: There is a risk assumed by individuals who use this type of equipment. To minimize risk always follow these rules.

- 1) It is essential that you consult with your physician before beginning any exercise program.
- 2) Inspect equipment before each use for loose, worn, or frayed parts (including cables, nuts and bolts). Replace parts at first signs of wear (use only genuine BATCA replacement parts). Use of equipment that is damaged, worn, frayed or not completely assembled on a solid, level surface may result in injury.
- 3) Make sure all adjustment pins are fully engaged before using equipment.
- 4) Keep all parts of the body and clothing outside the path of any moving parts of the gym. Be alert to the possibility of injury. Do not be careless.
- 5) Minors and children should not be allowed to play on or around this gym.
- 6) If you have any questions on proper use or maintenance of this gym, do not hesitate to call your local BATCA FITNESS SYSTEMS distributor or BATCA FITNESS SYSTEMS at (919) 255-1233. www.batcafitness.com

Table of Contents

	<u>Page</u>		<u>Page</u>
Instructions	2	Maintenance	18
Tools Required/Hardware	3-4	Warranty	19
AXIS Floor Anchoring Guide	5	Floor Plan Layout	20
AXIS Unit Connection Assembly	6-12		
AXIS Freeweight Rack Assembly	13-17		

Tools Required For Freeweight Rack

- 9/16" Wrench/Ratchet
- Metric Allen Wrench Set (M8, M6, M4)
- 3/4" Wrench
- Tape Measure

Tools Required For Complete AXIS System

- 9/16" Wrench/Ratchet
- Metric Allen Wrench Set (M8, M6, M4)
- 3/4" Wrench
- Tape Measure

Hardware Blister Packs

AXIS Shelf Connector A Hardware

(For Assembly Section starting on pg. 5 of this Manual)

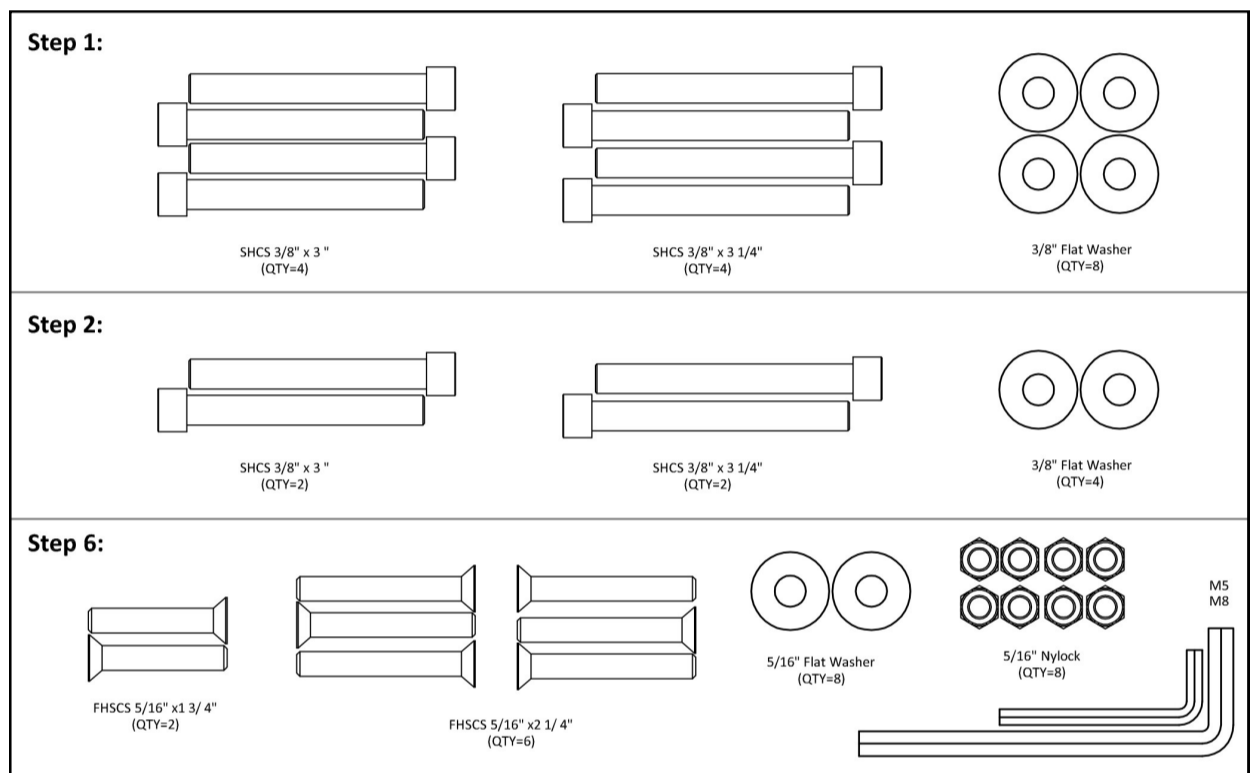

AXIS Shelf Connector B Hardware

(For Assembly Section starting on pg. 5 of this Manual)

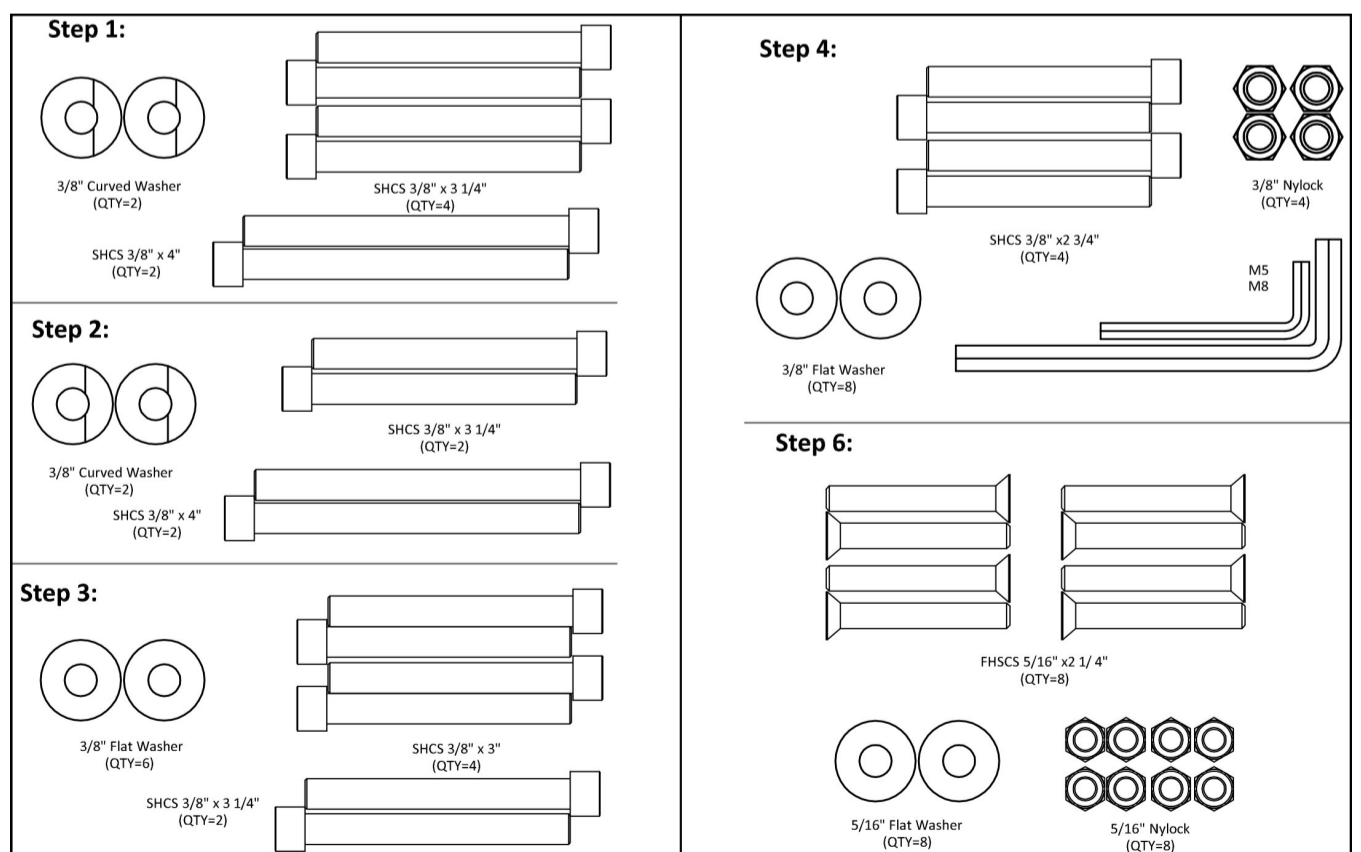

Hardware Blister Packs

AXIS Freeweight Rack Hardware

(Some of the hardware from Step 1 will be used if connecting 2 or more Main AXIS Units in the section called Modular Connection Assembly starting at pg. 6. The rest of the hardware will be used in the next section AXIS Freeweight Rack Assembly starting on pg.13.)

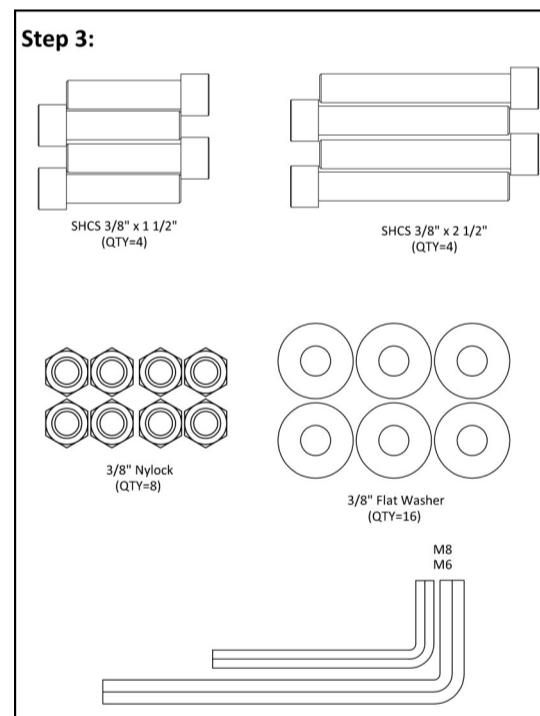
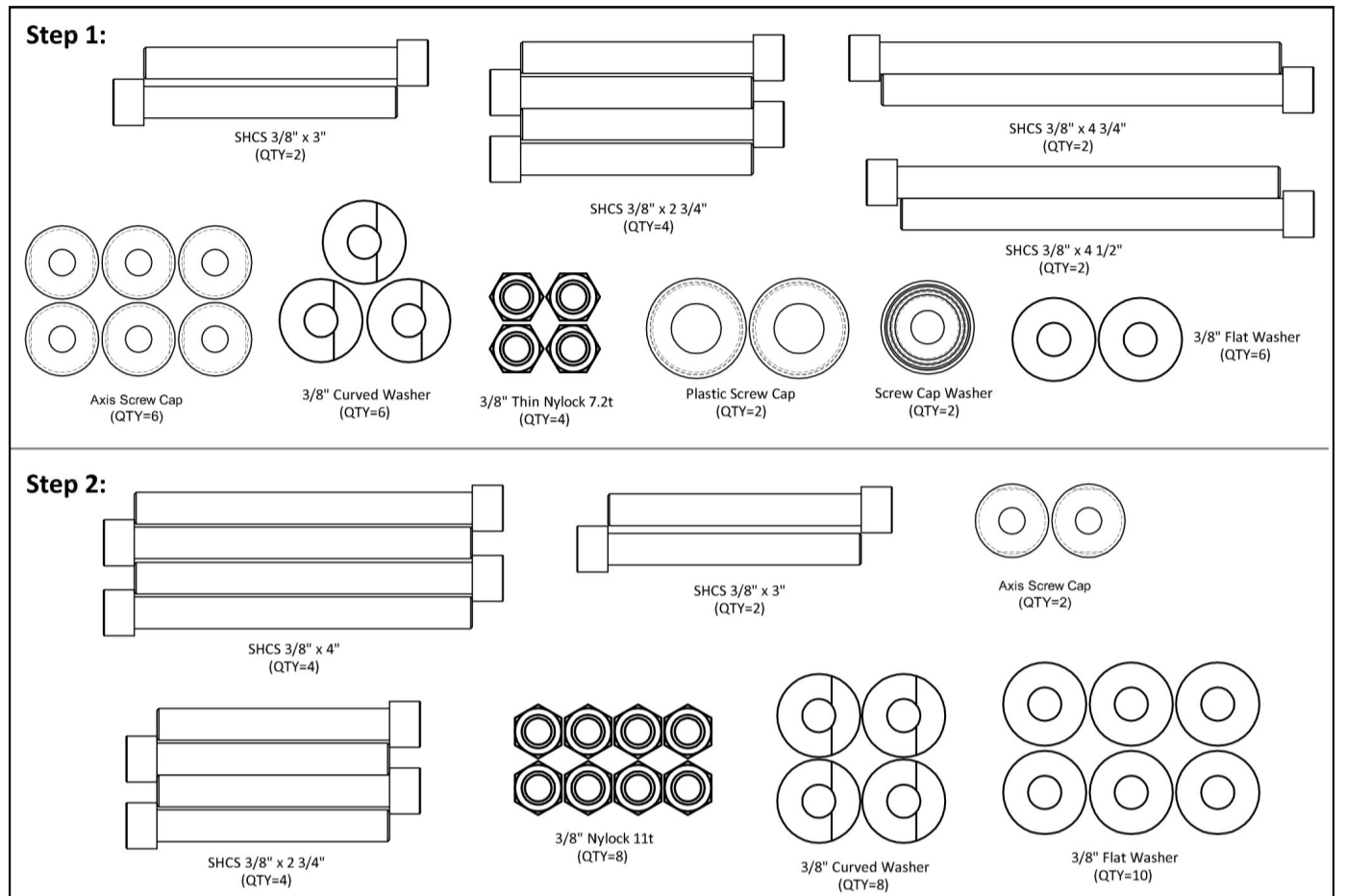

Floor Anchoring

! Please be sure to read and follow all floor anchoring instructions when assembling and installing BATCA AXIS Units. The actual floor anchoring instructions are included in the AXIS FLOOR ANCHOR KIT. This page illustrates the configurations that require anchoring before they are safe to use.

Single Station Configuration

(Pictured Left)

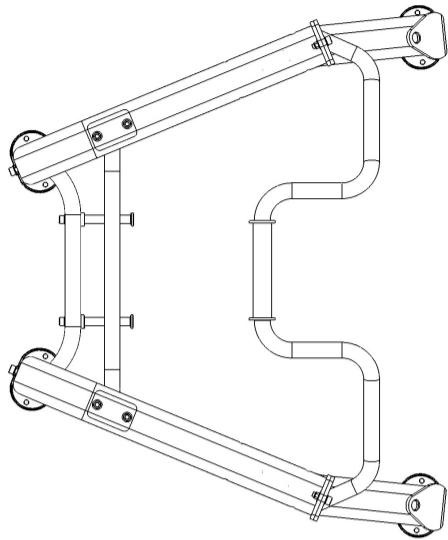

In order to prevent shifting or tipping: The AXIS Bodyweight Trainer, AXIS Smith Trainer, or AXIS Freeweight Rack must be anchored to the floor using the AXIS FLOOR ANCHOR KIT before use.

(The AXIS Free Trainer does not need to be anchored to the floor if sold as a single unit.)

Two Station Configuration

(Pictured left)

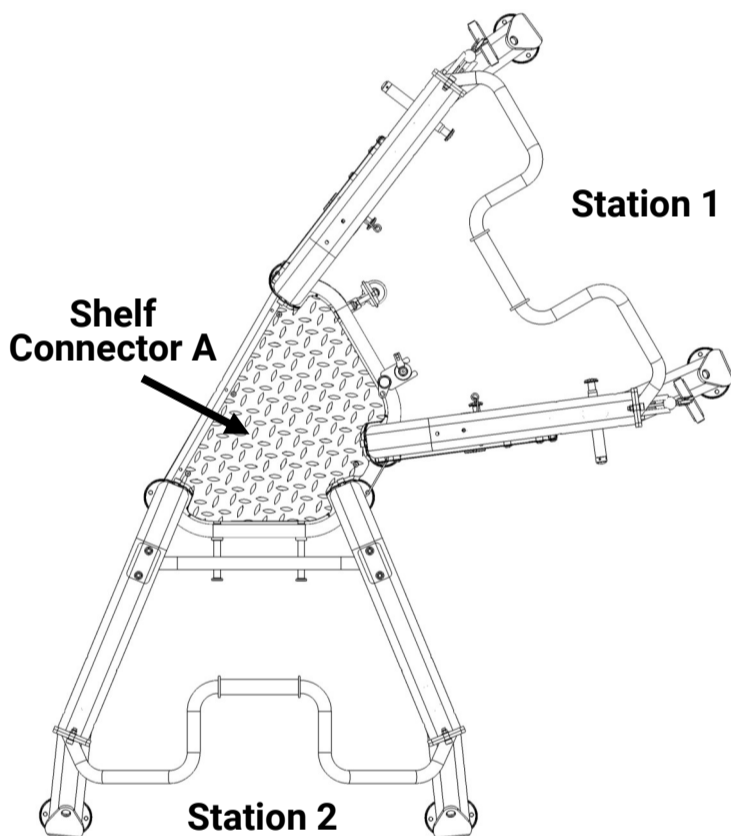

In order to prevent shifting or tipping: If installing and connecting any combination of two of the AXIS Free Trainer, The AXIS Bodyweight Trainer, AXIS Smith Trainer, or AXIS Freeweight Rack with the AXIS Shelf Connector A, both stations must be anchored to the floor using the AXIS FLOOR ANCHOR KIT before use.

Three Station Configuration

(Pictured Left)

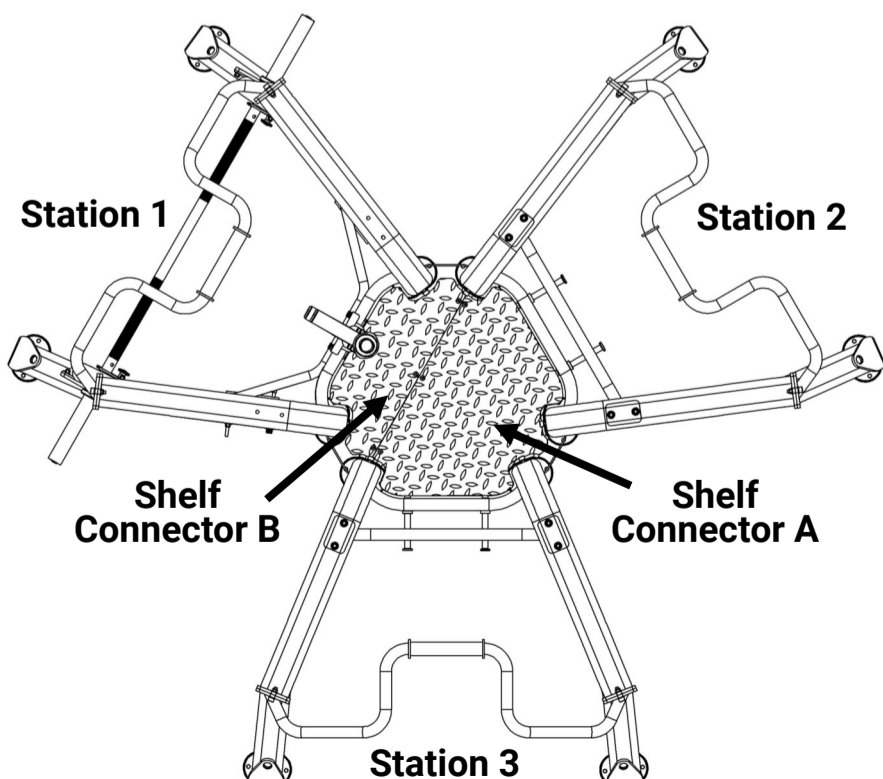

In order to prevent shifting: If installing and connecting any combination of three of The AXIS Bodyweight Trainer, AXIS Smith Trainer, or AXIS Freeweight Rack with the AXIS Shelf Connector A and the AXIS Shelf Connector B, all stations must be anchored to the floor using the AXIS FLOOR ANCHOR KIT before use.

(If the AXIS Free Trainer is one of the three units being connected in the Three Station Configuration shown in the photo, floor anchors are not required.)

PLEASE FOLLOW ALL DIRECTIONS VERY CAREFULLY FOR PROPER INSTALLATION. START AT THIS SECTION ONLY IF YOU PURCHASED AND ARE CONNECTING 2 OR MORE AXIS MAIN UNITS. THE AXIS MAIN UNITS ARE: AXIS FREE TRAINER, AXIS BODYWEIGHT TRAINER, AXIS SMITH TRAINER, AND AXIS FREEWEIGHT RACK. IF YOU ARE NOT CONNECTING 2 OR MORE OF THESE AXIS MAIN UNITS TOGETHER THEN SKIP AHEAD TO THE SECTION "AXIS FREEWEIGHT RACK ASSEMBLY ONLY" ON PAGE 13.

AXIS

MODULAR UNIT CONNECTION ASSEMBLY FOR AXIS MODULAR FREEWEIGHT RACK



! IN ORDER TO COMPLETE THIS SECTION OF THE ASSEMBLY MANUAL YOU WILL NEED TO UNPACK COMPONENTS FROM ALL AXIS MAIN UNITS THAT YOU ARE PLANNING TO CONNECT TO THE AXIS FREEWEIGHT RACK FROM THIS ASSEMBLY MANUAL. THE HARDWARE USED IN THIS SECTION WILL BE PACKAGED WITH THE AXIS SHELF CONNECTOR A AND AXIS SHELF CONNECTOR B (IF PURCHASED) ASSEMBLY. YOU MAY HAVE EXTRA HARDWARE LEFT OVER FROM THE HARDWARE PACK FROM THE AXIS MAIN UNITS IF YOU ARE CONNECTING 2 OR MORE MAIN AXIS UNITS.

PLEASE READ AND FOLLOW ALL DIRECTIONS VERY CAREFULLY FOR PROPER INSTALLATION.

Step 1:

Note: Please Position Hardware in the same direction as shown in the figure. This will make future steps easier to assemble

All Flat Washers and Nylocks are 3/8" unless otherwise noted. Anywhere a washer is against the round side of a tube there is to be a 3/8" CURVED WASHER instead of a 3/8" FLAT WASHER.

DO NOT TIGHTEN BOLTS

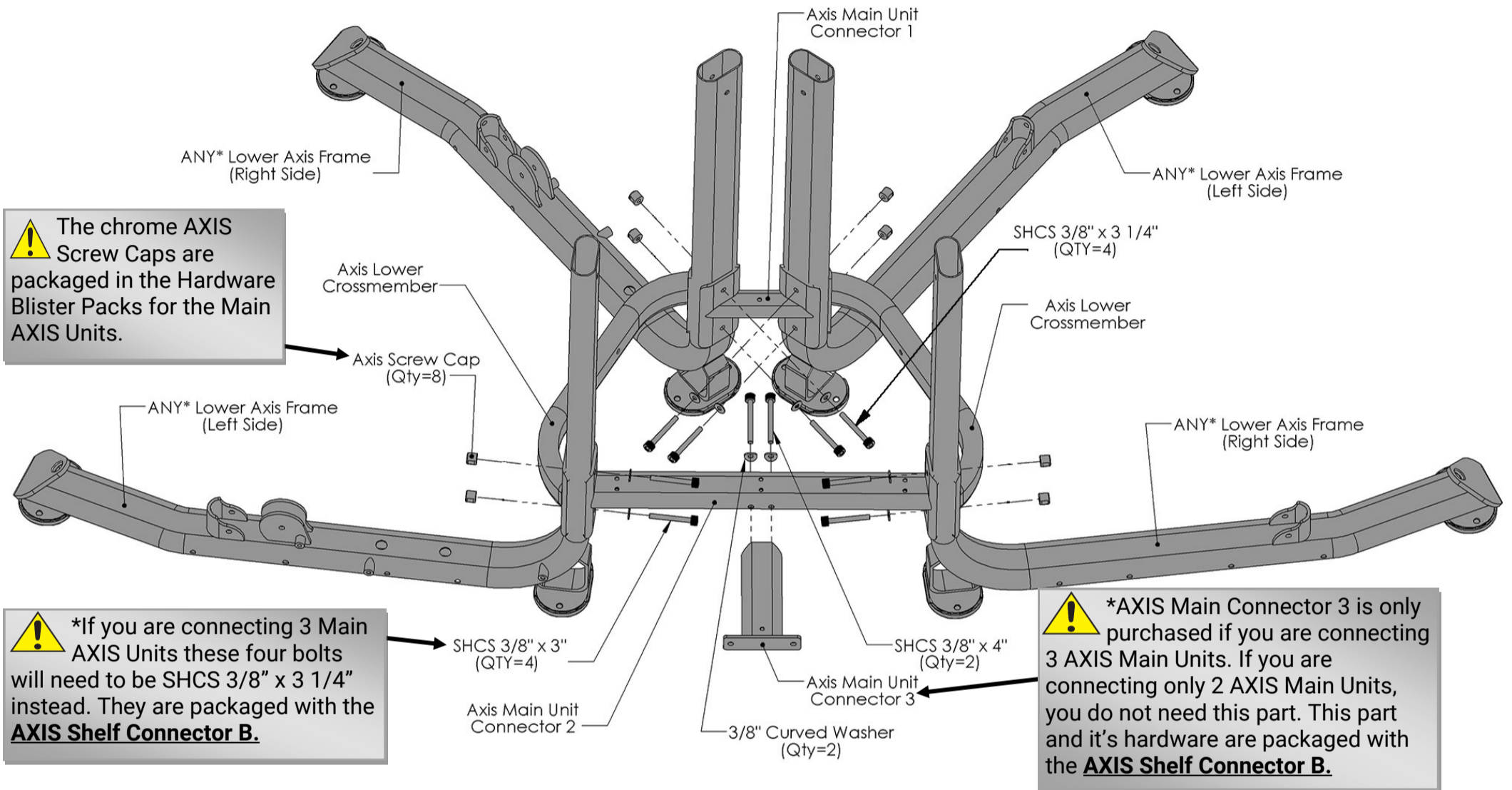

! The chrome **AXIS Screw Caps** are packaged in the **Hardware Blister Packs** for the **Main AXIS Units**.

! *If you are connecting 3 Main **AXIS Units** these four bolts will need to be **SHCS 3/8" x 3 1/4"** instead. They are packaged with the **AXIS Shelf Connector B**.

! ***AXIS Main Connector 3** is only purchased if you are connecting 3 **AXIS Main Units**. If you are connecting only 2 **AXIS Main Units**, you do not need this part. This part and it's hardware are packaged with the **AXIS Shelf Connector B**.

! *The **ANY* Axis** parts Note above is referring to the fact that any combination of the **Axis Free Trainer**, the **Axis Bodyweight Trainer**, The **Axis Smith Machine**, or the **Axis Freeweight Rack** can be assembled together in any configuration. Regardless of which of these combinations are installed together the instructions for installation are the same. Please keep the parts from the **Main Units** separate from each other to avoid confusion during assembly.

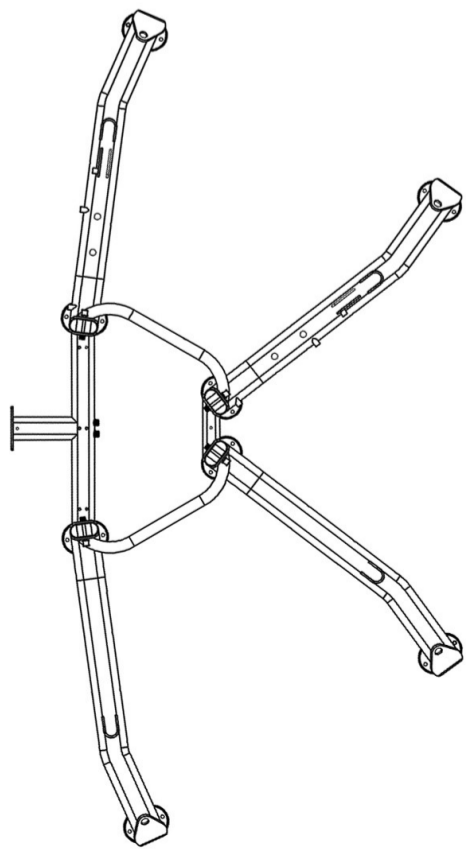

Part #	Description	Qty
Refer to Manual of Corresponding AXIS Unit	ANY* Lower Axis Frame (Right Side)	2
Refer to Manual of Corresponding AXIS Unit	ANY* Lower Axis Frame (Left Side)	2
BFM-11097	Axis Lower Cross-Member	2
BFM-11134	Axis Main Unit Connector 1	1
BFM-11135	Axis Main Unit Connector 2	1
BFM-11133	Axis Main Unit Connector 3	1
BFM-52813	AXIS Screw Cap	8
BFP-51747	SHCS 3/8" x 3"	4
BFP-51748	SHCS 3/8" x 3 1/4"	4
BFP-52345	SHCS 3/8" x 4"	2
BFH-50204	3/8" Curved Washer	2
BFH-50146	3/8" Flat Washer	8



Step 2:

All Flat Washers and Nylocks are 3/8" unless otherwise noted. Anywhere a washer is against the round side of a tube there is to be a 3/8" **CURVED WASHER** instead of a 3/8" **FLAT WASHER**.



DO NOT TIGHTEN BOLTS

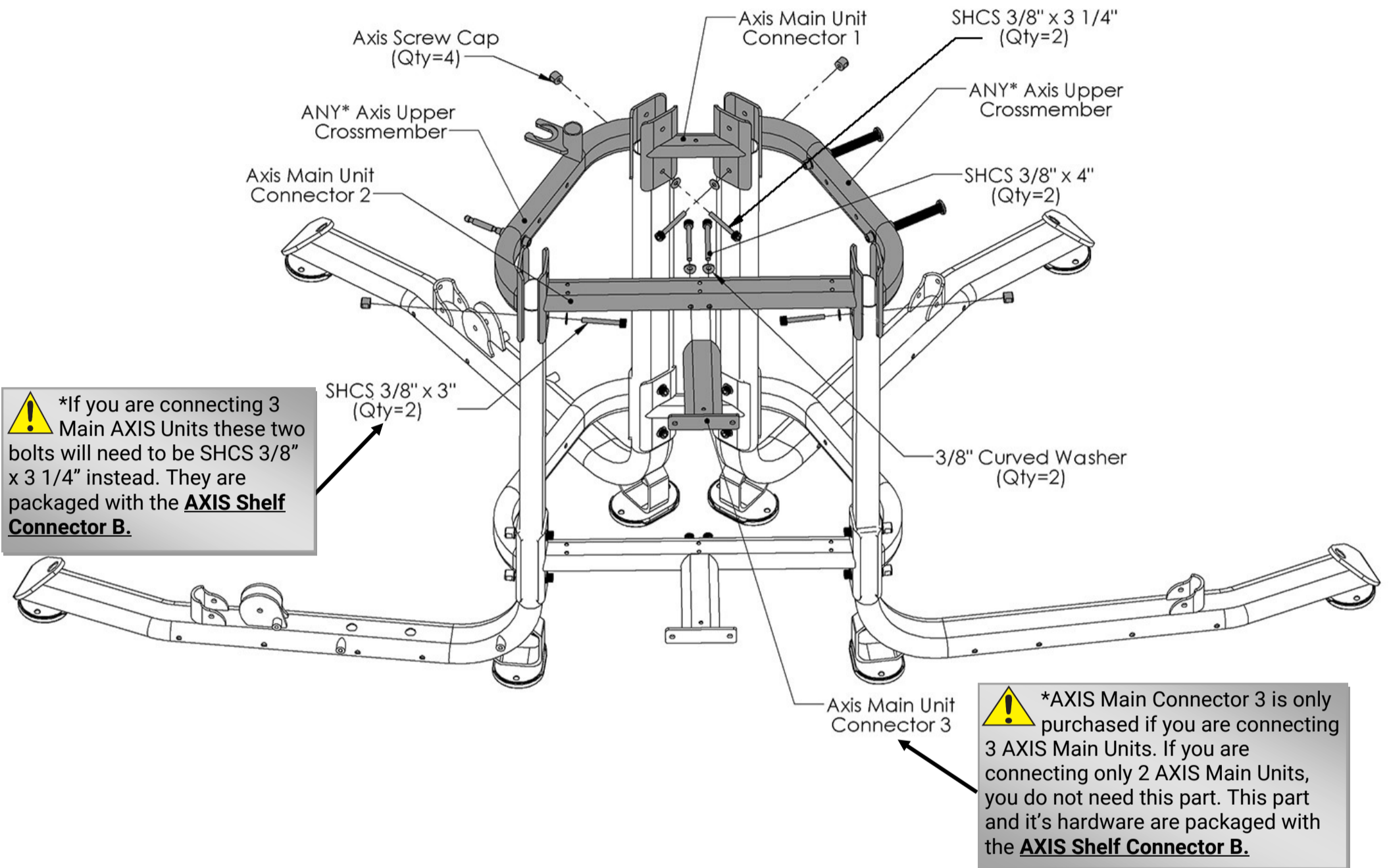

***The **ANY* Axis** parts Note above is referring to the fact that any combination of the Axis Free Trainer, the Axis Bodyweight Trainer, The Axis Smith Trainer or the Axis Freeweight Rack can be assembled together in any configuration. Regardless of which of these combinations are installed together the instructions for installation are the same. Please keep the parts from the Main Units separate from each other to avoid confusion during assembly.**

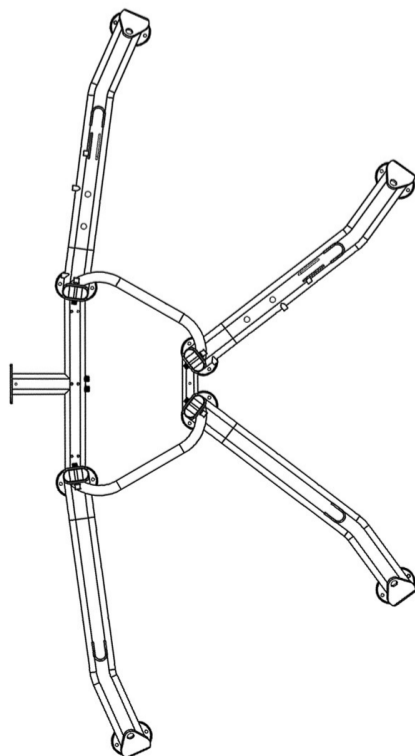

Part #	Description	Qty
Refer to Manual of Corresponding AXIS Unit	ANY* AXIS Upper Cross-Member	2
BFM-11134	Axis Main Unit Connector 1	1
BFM-11135	Axis Main Unit Connector 2	1
BFM-11133	Axis Main Unit Connector 3	1
BFM-52813	AXIS Screw Cap	4
BFP-51747	SHCS 3/8" x 3"	2
BFP-51748	SHCS 3/8" x 3 1/4"	2
BFP-52345	SHCS 3/8" x 4"	2
BFH-50204	3/8" Curved Washer	2
BFH-50146	3/8" Flat Washer	4

IF ONLY 2 AXIS MAIN UNITS ARE BEING CONNECTED PLEASE SKIP TO STEP 5 PAGE 9. THIS STEP IS ONLY IF YOU ARE CONNECTING 3 AXIS MAIN UNITS. HARDWARE FOR THIS STEP IS PACKAGED WITH THE AXIS SHELF CONNECTOR B



Step 3:

All Flat Washers and Nylocks are 3/8" unless otherwise noted. Anywhere a washer is against the round side of a tube there is to be a 3/8" *CURVED WASHER* instead of a 3/8" *FLAT WASHER*.

DO NOT TIGHTEN BOLTS

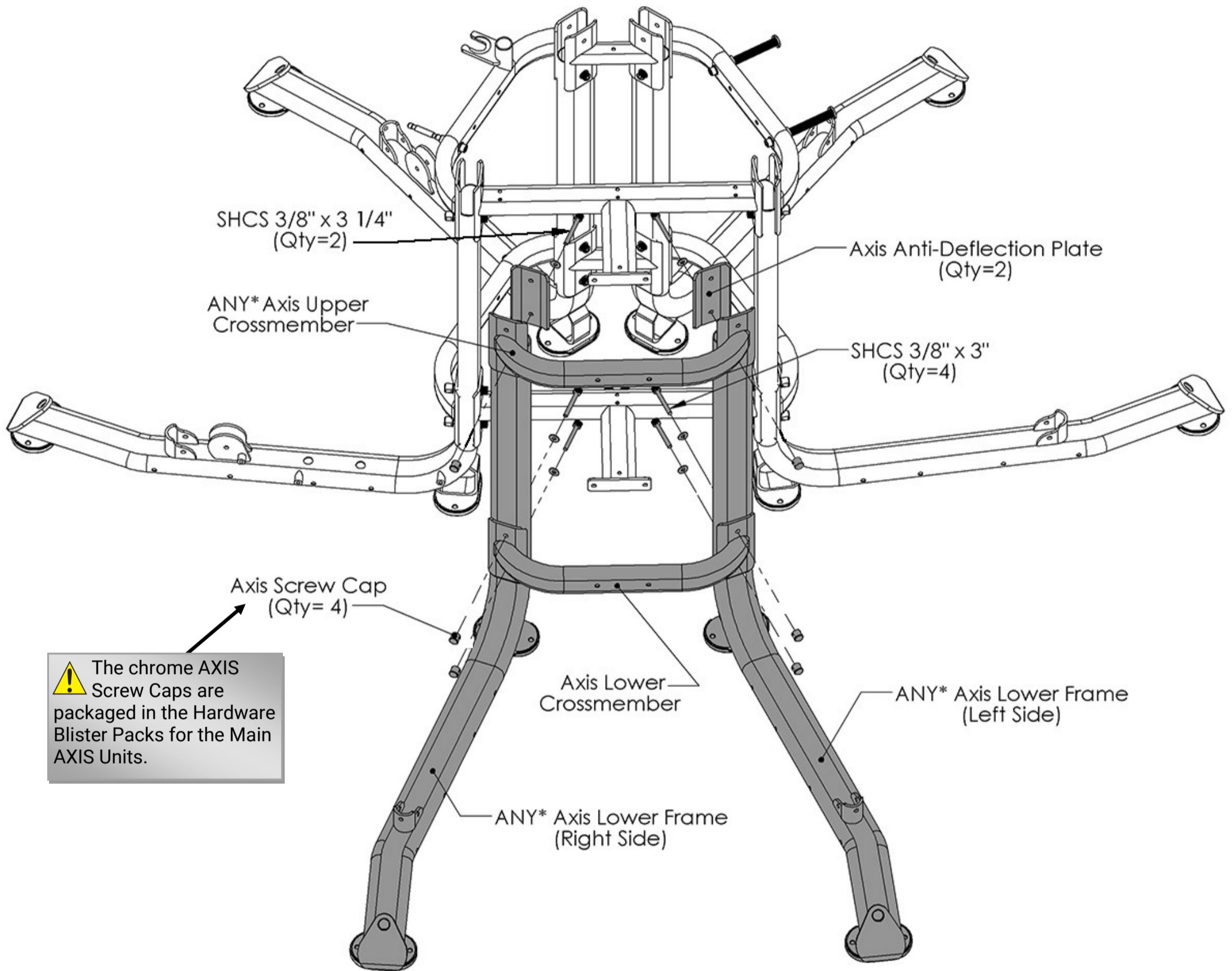

! The chrome **AXIS** Screw Caps are packaged in the Hardware Blister Packs for the Main **AXIS** Units.

Part #	Description	Qty
Refer to Manual of Corresponding AXIS Unit	ANY* Lower Axis Frame (Right Side)	2
Refer to Manual of Corresponding AXIS Unit	ANY* Lower Axis Frame (Left Side)	2
BFM-11097	Axis Lower Cross-Member	1
Refer to Manual of Corresponding AXIS Unit	ANY* AXIS Upper Cross-Member	1
BFM-52618	AXIS Anti-Deflection Plate	2
BFM-52813	AXIS Screw Cap	6
BFP-51747	SHCS 3/8" x 3"	4
BFP-51748	SHCS 3/8" x 3 1/4"	2
BFH-50146	3/8" Flat Washer	6

HARWARE FOR THIS STEP IS PACKAGED WITH THE AXIS SHELF CONNECTOR B



Step 4:

All Flat Washers and Nylocks are 3/8" unless otherwise noted. Anywhere a washer is against the round side of a tube there is to be a 3/8" **CURVED WASHER** instead of a 3/8" **FLAT WASHER**.



DO NOT TIGHTEN BOLTS

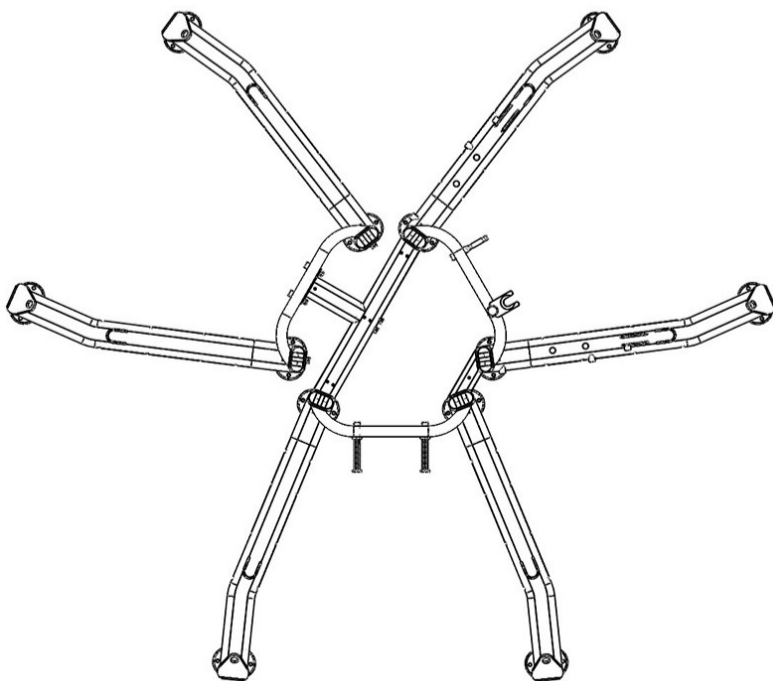
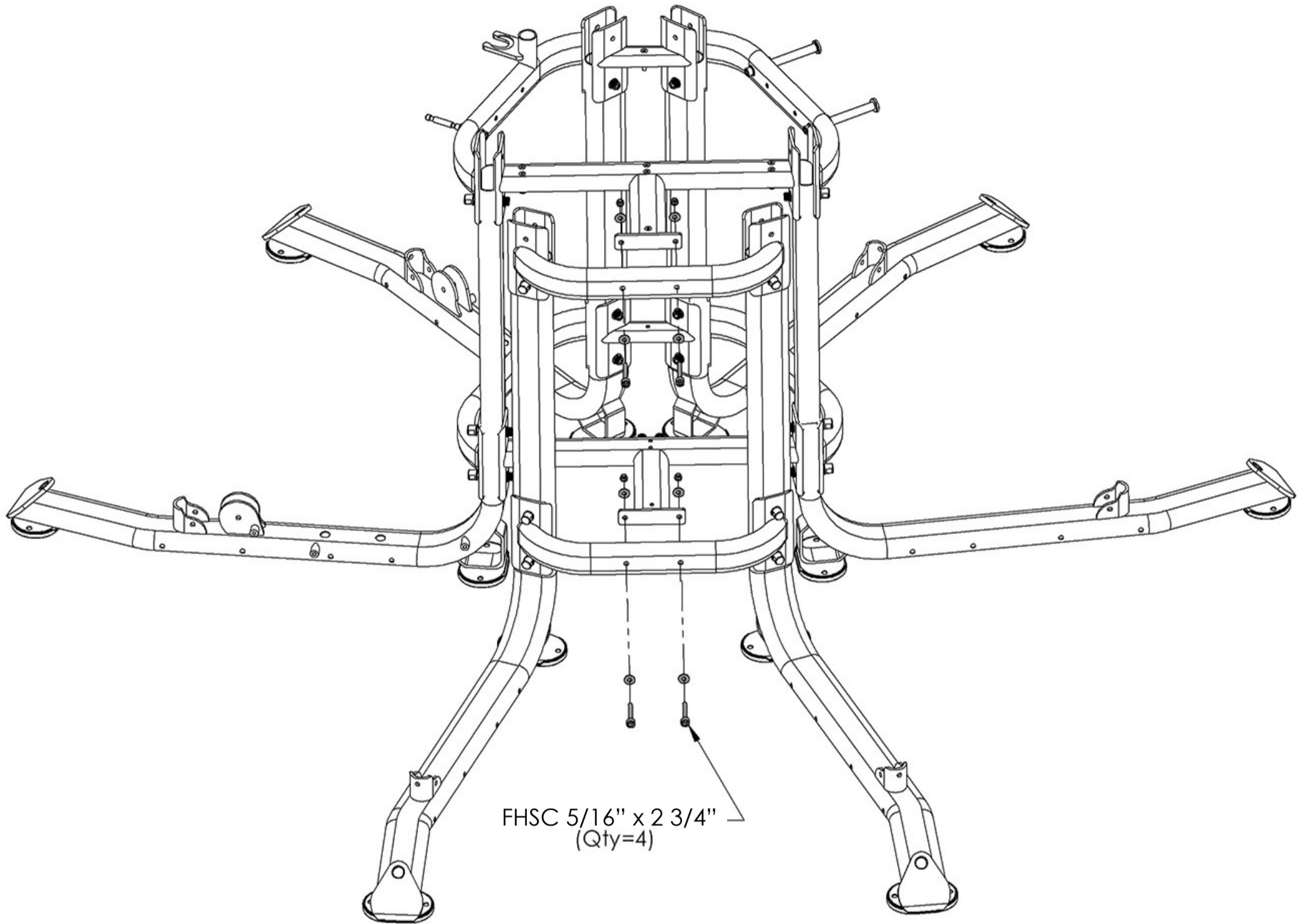

Part #	Description	Qty
BFP-51750	SHCS 3/8" x 2 3/4"	4
BFH-50146	3/8" Flat Washer	8
BFH-50157	3/8" Nylock	4



Step 5:

All Flat Washers and Nylocks are 3/8" unless otherwise noted. Anywhere a washer is against the round side of a tube there is to be a 3/8" **CURVED WASHER** instead of a 3/8" **FLAT WASHER**.

 **DO NOT TIGHTEN BOLTS**

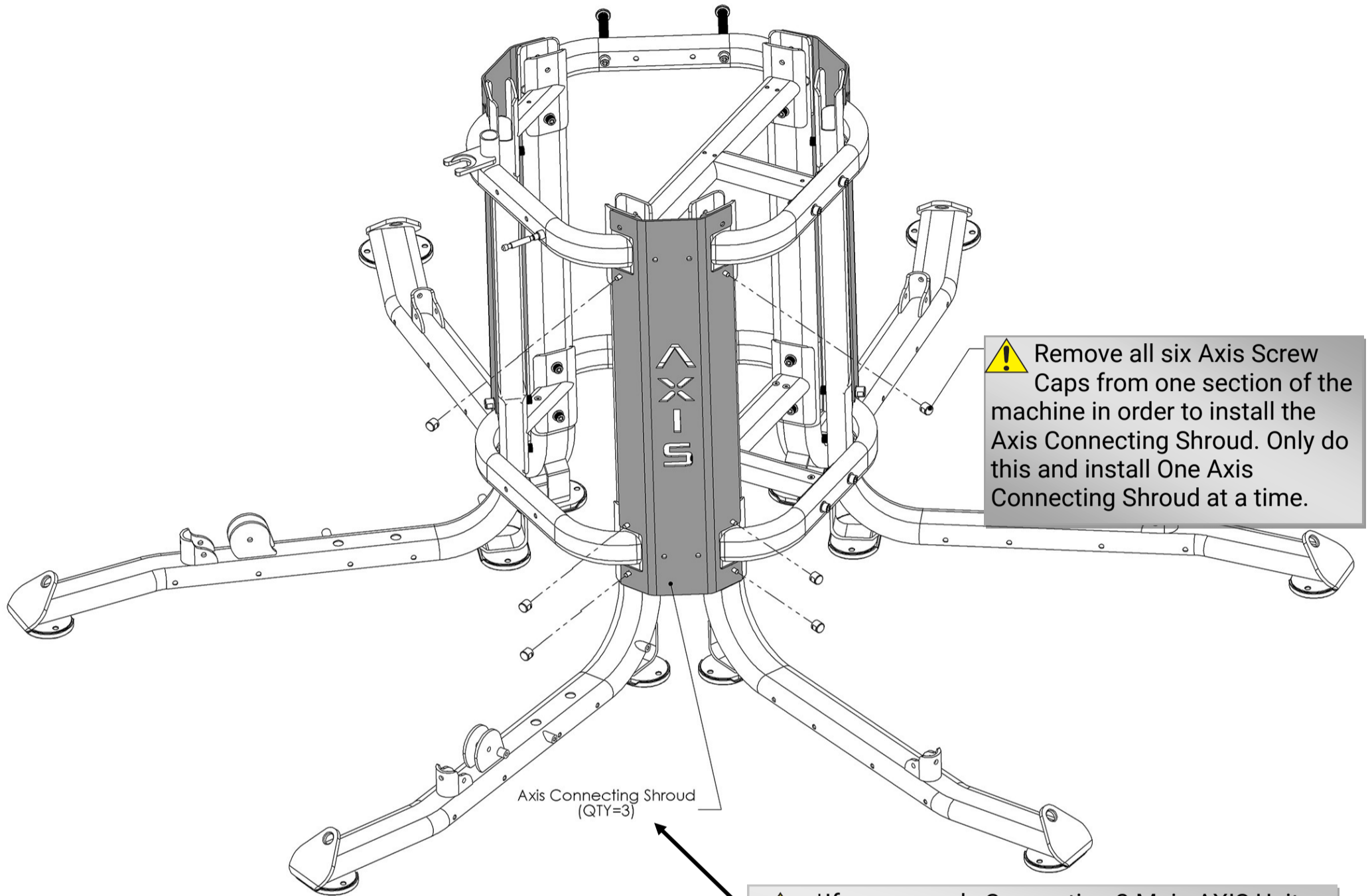

 Remove all six Axis Screw Caps from one section of the machine in order to install the Axis Connecting Shroud. Only do this and install One Axis Connecting Shroud at a time.

Axis Connecting Shroud (QTY=3)

 *If you are only Connecting 2 Main AXIS Units then you will only have 1 AXIS Connecting Shroud. You will only have all three AXIS Connecting Shrouds if you are Connecting 3 Main AXIS Units and purchase the **AXIS Shelf Connector B**.

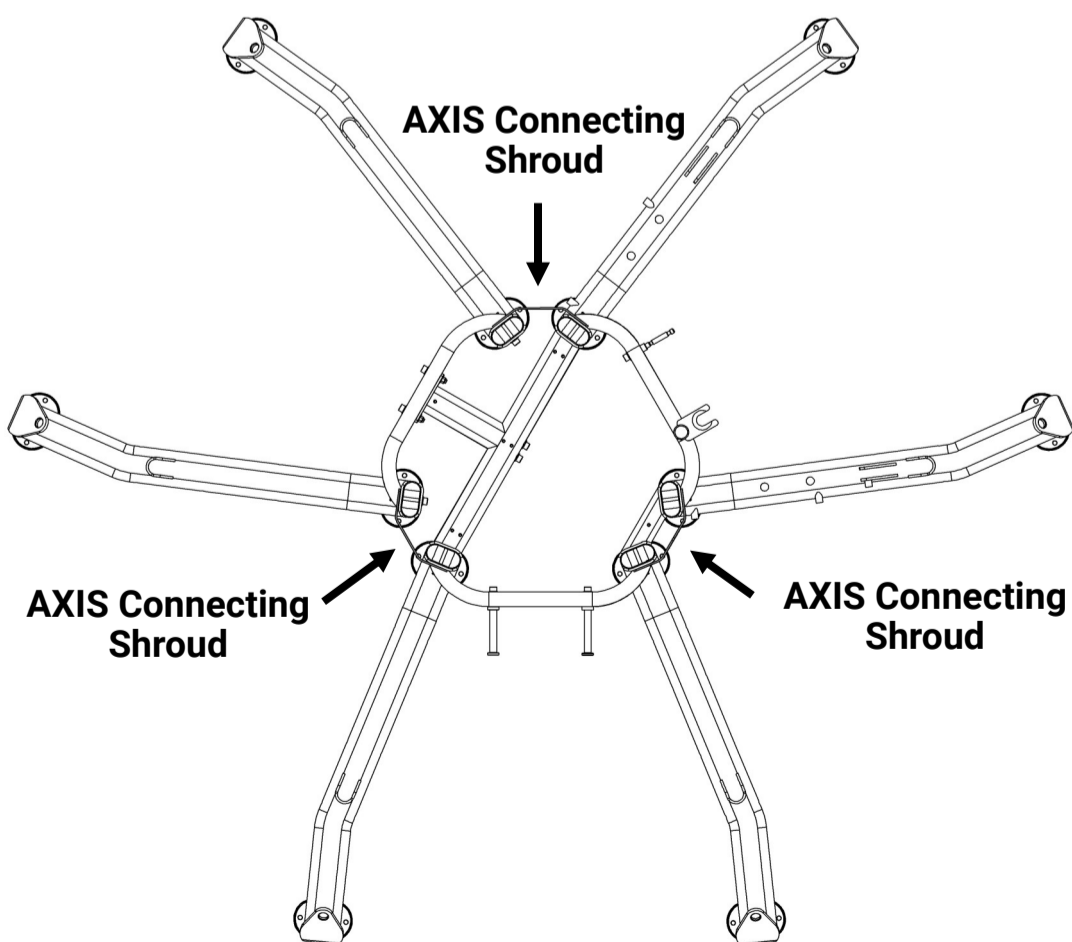

Part #	Description	Qty
BFM-52727	AXIS Connecting Shroud	3



Step 6:

All Flat Washers and Nylocks are 3/8" unless otherwise noted. Anywhere a washer is against the round side of a tube there is to be a 3/8" **CURVED WASHER** instead of a 3/8" **FLAT WASHER**.



DO NOT TIGHTEN BOLTS



*If you are only Connecting 2 Main AXIS Units then you will not have the AXIS Shelf Plate 2 or the Hardware listed here for it. The AXIS Shelf Plate 2 and its hardware are needed only when connecting 3 AXIS Main Units. These parts are packaged with the **AXIS Shelf Connector B**.

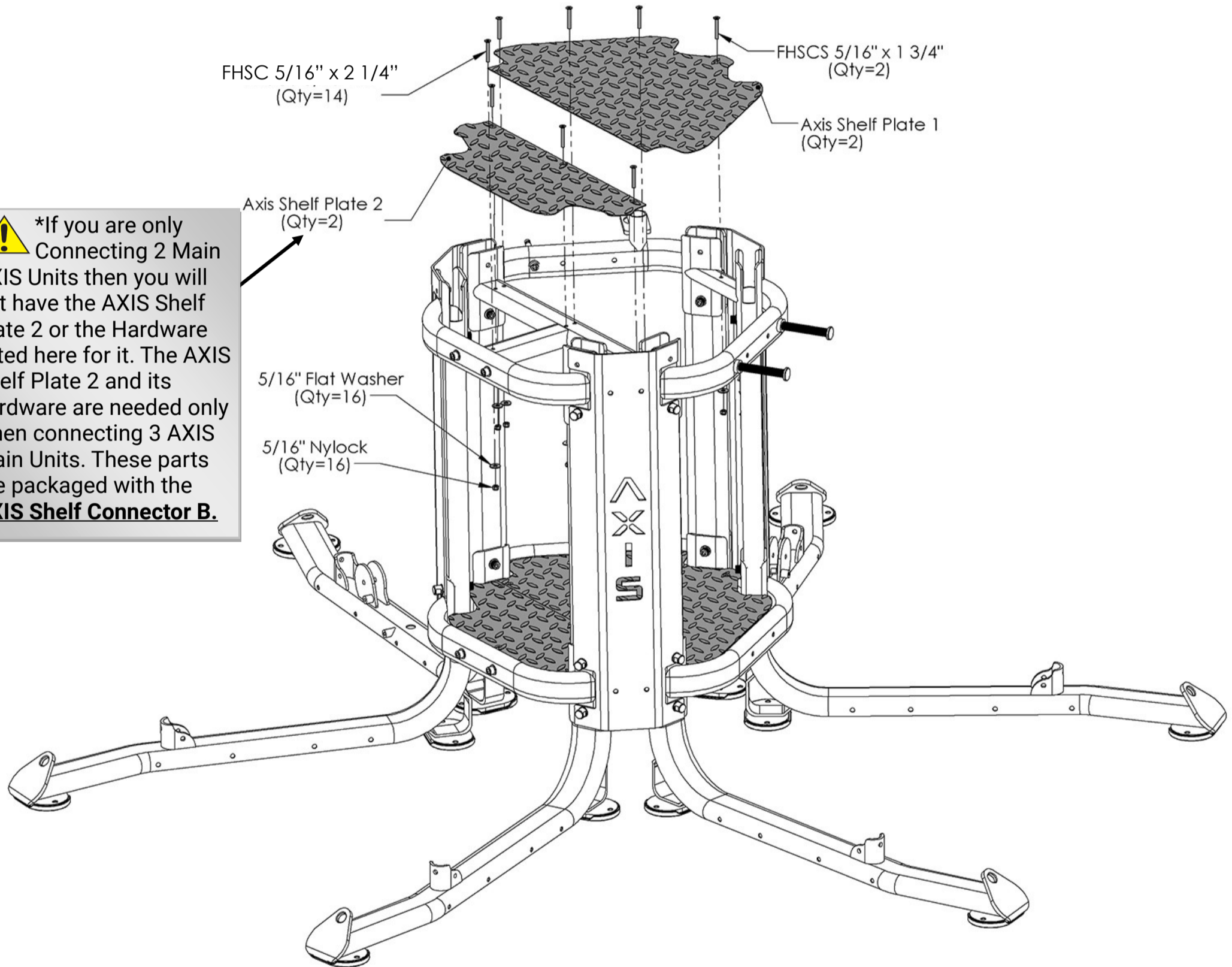

Part #	Description	Qty
BFM-52729	AXIS Shelf Plate 1	2
BFM-52730	AXIS Shelf Plate 2	2
BFH-51611	FHSCS 5/16" x 1 3/4"	2
BFH-52545	FHSCS 5/16" x 2 1/4"	14
BFH-51612	5/16" Flat Washer	16
BFH-50267	5/16" Nylock	16

PLEASE FOLLOW ALL DIRECTIONS VERY CAREFULLY FOR PROPER INSTALLATION. START AT THIS SECTION ONLY IF YOU PURCHASED THE AXIS FREEWEIGHT RACK AS A STAND ALONE UNIT. IF YOU ARE CONNECTING 2 OR MORE AXIS UNITS TOGETHER THEN GO BACK AND START AT PAGE 6 BEFORE CONTINUING TO THIS SECTION.

AXIS

FOR AXIS FREEWEIGHT RACK
ASSEMBLY ONLY





Step 1:

Note: Please Position Hardware in the same direction as shown in the figure. This will make future steps easier to assemble

All Flat Washers and Nylocks are 3/8" unless otherwise noted. Anywhere a washer is against the round side of a tube there is to be a 3/8" CURVED WASHER instead of a 3/8" FLAT WASHER.



DO NOT TIGHTEN BOLTS

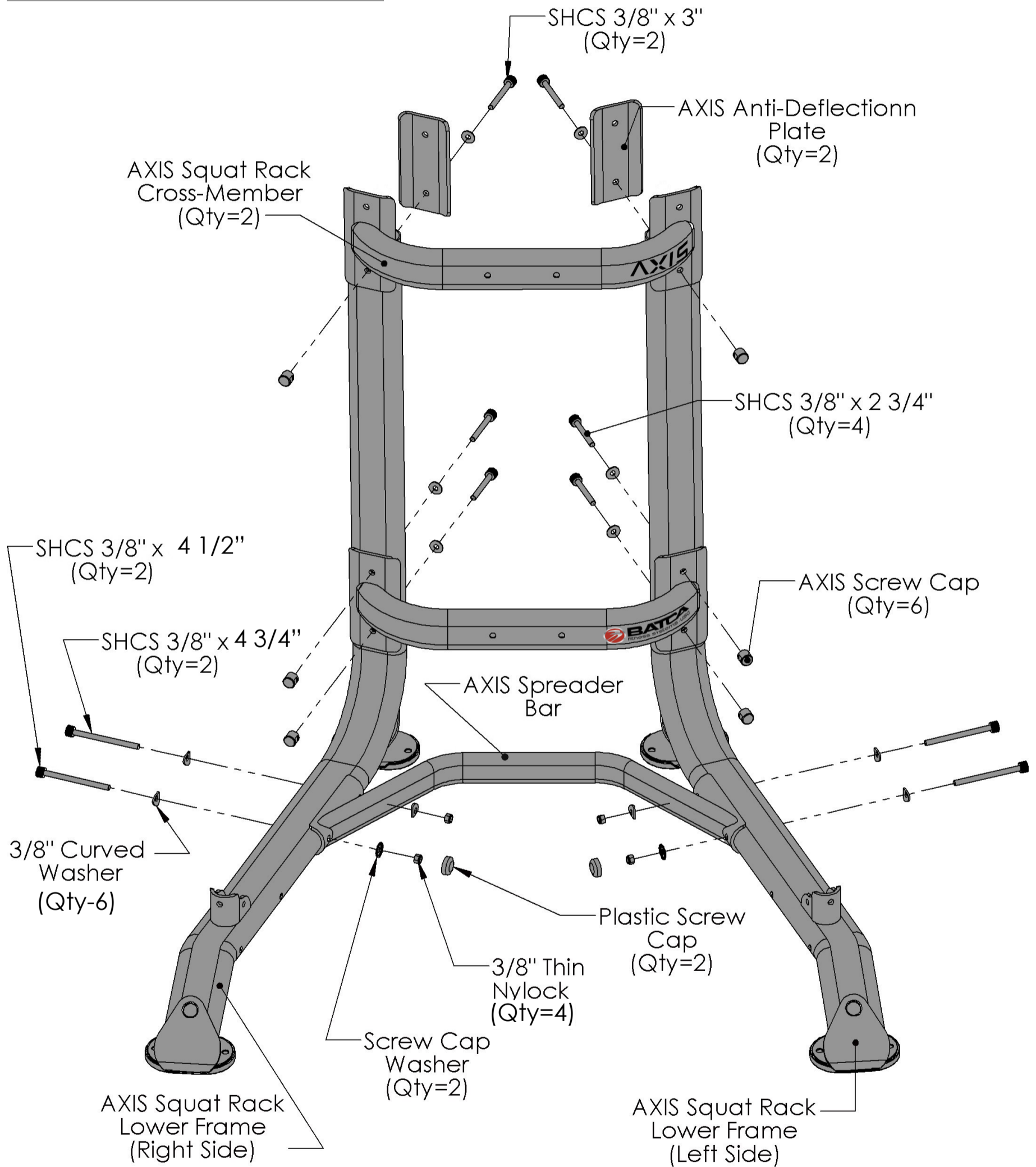

Part #	Description	Qty
BFM-11141	AXIS Freeweight Rack Lower Frame Assembly (Right Side)	1
BFM-11140	AXIS Freeweight Rack Lower Frame Assembly (Left Side)	1
BFM-11111	AXIS Freeweight Rack Cross-Member	2
BFM-11159	AXIS Freeweight Rack Spreader Bar	1
BFM-52618	AXIS Anti-Deflection Plate	2
BFM-52813	AXIS Screw Cap	6

BFP-51750	SHCS 3/8" x 2 3/4"	4
BFP-51747	SHCS 3/8" x 3"	2
BFP-51751	SHCS 3/8" x 4 1/2"	2
BFP-51753	SHCS 3/8" x 4 3/4"	2
BFH-50113	Screw Cap Washer	2
BFH-50112	Plastic Screw Cap Cover	2
BFH-50204	3/8" Curved Washer	6
BFH-50146	3/8" Flat Washer	6
BFH-50247	3/8" Thin Nylock	4



Step 2:

All Flat Washers and Nylocks are 3/8" unless otherwise noted. Anywhere a washer is against the round side of a tube there is to be a 3/8" **CURVED WASHER** instead of a 3/8" **FLAT WASHER**.

DO NOT TIGHTEN BOLTS

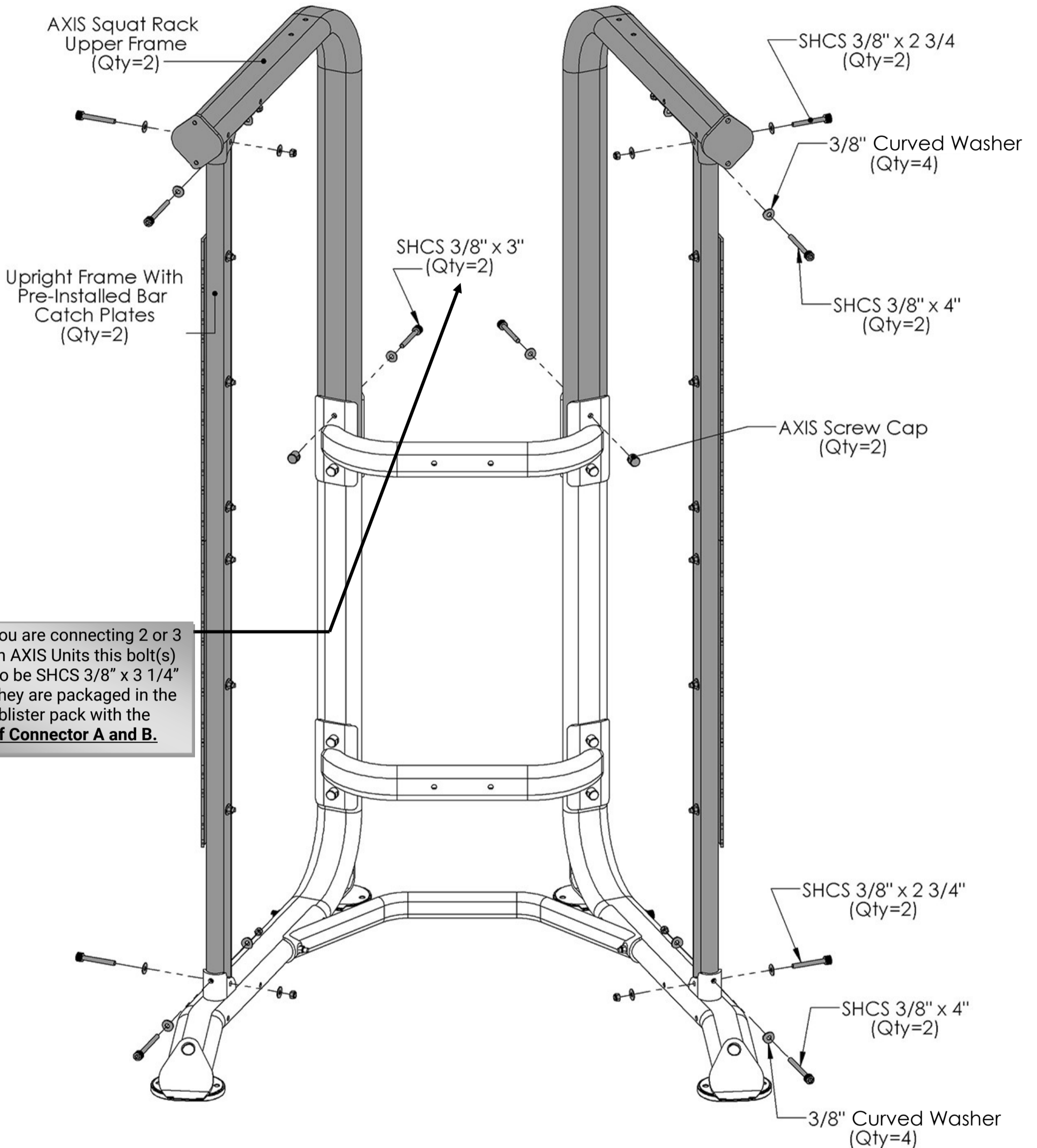

! *If you are connecting 2 or 3 Main AXIS Units this bolt(s) will need to be SHCS 3/8" x 3 1/4" instead. They are packaged in the hardware blister pack with the **AXIS Shelf Connector A and B**.

Part #	Description	Qty
BFM-11139	AXIS Free Weight Rack Upper Frame	2
BFM-11170	Upright Frame Assembly with Pre-installed Bar Racking Plate (Right Side)	1
BFM-11171	Upright Frame Assembly with Pre-installed Bar Racking Plate (Left Side)	1
BFM-52813	AXIS Screw Cap	2
BFP-51750	SHCS 3/8" x 2 3/4"	4
BFP-51747	SHCS 3/8" x 3"	2
BFP-52345	SHCS 3/8" x 4"	4
BFH-50204	3/8" Curved Washer	8
BFH-50146	3/8" Flat Washer	10
BFH-50157	3/8" Nylock	8



Step 3:

All Flat Washers and Nylocks are 3/8" unless otherwise noted. Anywhere a washer is against the round side of a tube there is to be a 3/8" **CURVED WASHER** instead of a 3/8" **FLAT WASHER**.

DO NOT TIGHTEN BOLTS

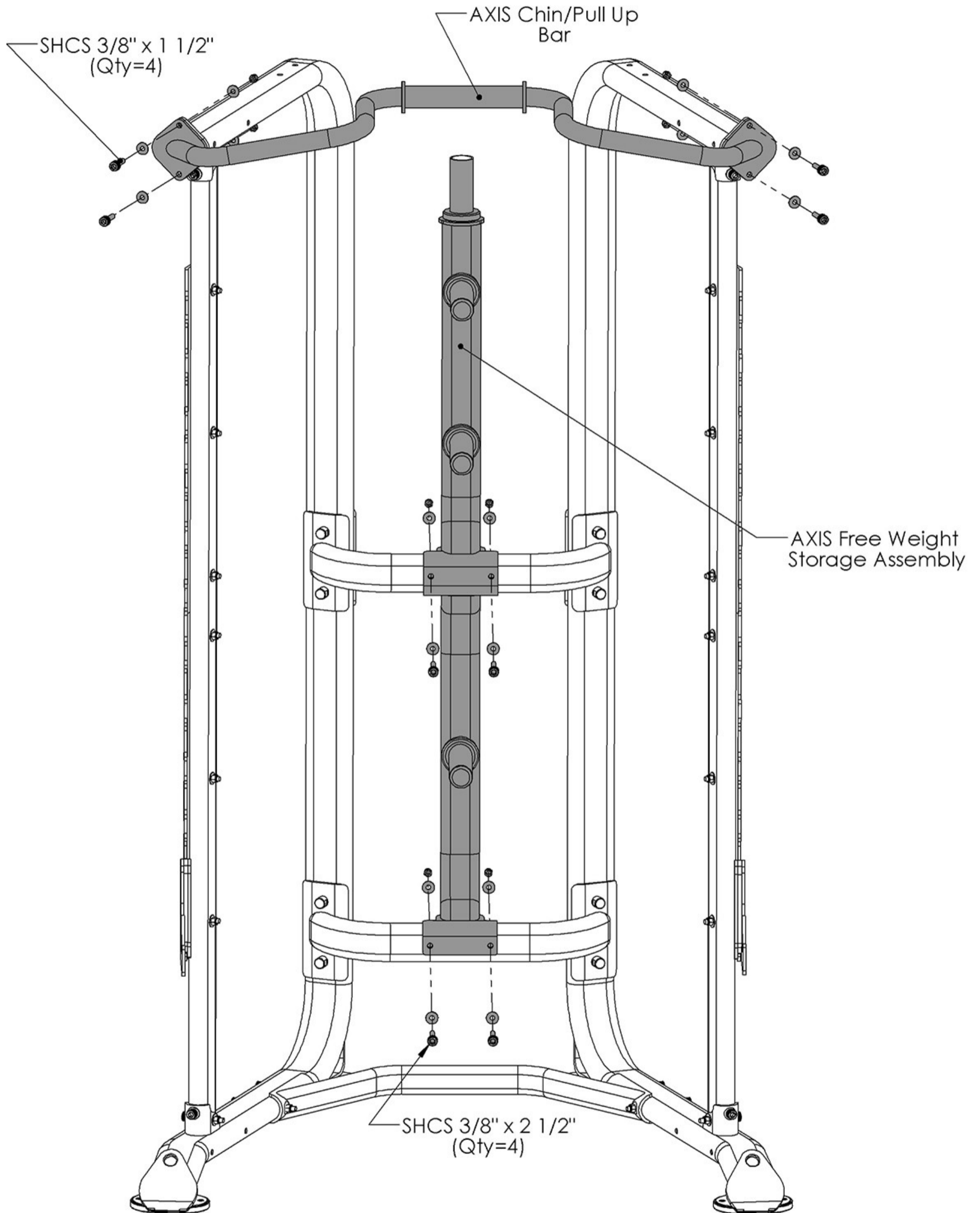

Part #	Description	Qty
BFM-11101	AXIS Chin/Pull Up Bar Assembly	1
BFM-11169	AXIS Free Weight Storage Assembly	1
BFP-51697	SHCS 3/8" 1 1/2"	4
BFP-51615	SHCS 3/8" x 2 1/2"	4
BFH-50146	3/8" Flat Washer	16
BFH-50157	3/8" Nylock	8



Step 3:

All Flat Washers and Nylocks are 3/8" unless otherwise noted. Anywhere a washer is against the round side of a tube there is to be a 3/8" **CURVED WASHER** instead of a 3/8" **FLAT WASHER**.



PLEASE TIGHTEN ALL BOLTS AT THE END OF COMPLETING THIS STEP.

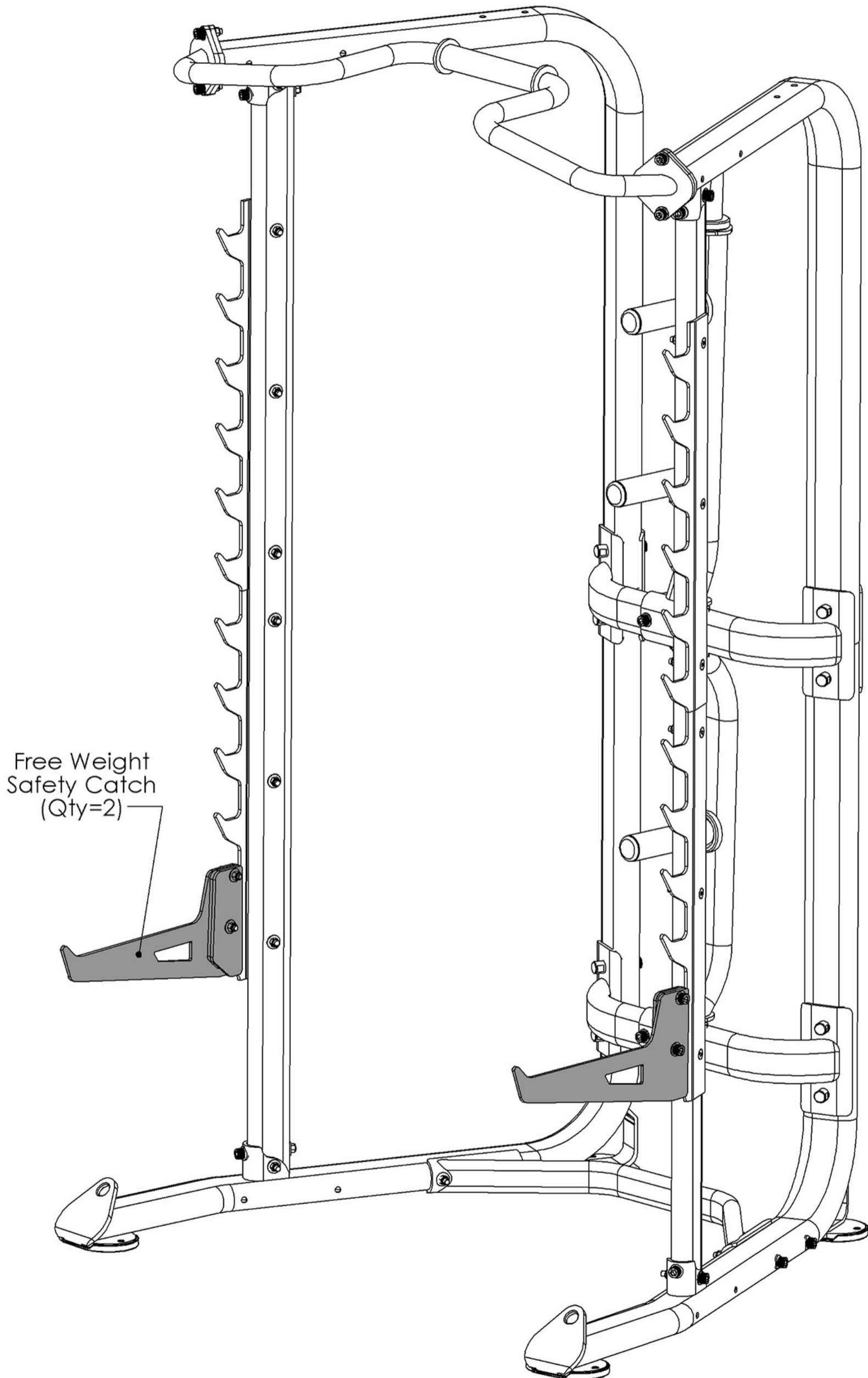

Part #	Description	Qty
BFP-11021	AXIS Free Weight Safety Catch	2

Preventive Maintenance

Batca Fitness Systems strives to give you the very best in quality, performance and safety through carefully engineered designs and excellent workmanship. In order to maintain this high level of quality the preventative maintenance schedule below should be followed.

Clean upholstery, grips, and roller pads with mild soap and water generally after every use. The guide rods, chrome slides and frame should be cleaned with a cotton cloth. Upon cleaning the guide rods, a thin layer of Silicone or Teflon gel should be applied to each rod to ensure a glass smooth performance.

An overall inspection should be done before each workout. If the warning and safety decals are worn or have been removed they should be replaced immediately. The cables and cable systems should be inspected for signs of wear and proper tension. In order to check cables properly you should carefully run the cable through your fingertips, checking for signs of wear, cracks, burs and thinning spots. Replace any part at first signs of wear. Cables should be adjusted for proper tension. See assembly instructions for this detail. All hardware, stops, and adjustments should be checked and tightened as required.

The guide rods on your machine should be cleaned and lubricated regularly. This will ensure a glass smooth performance from your weight stack. A thin layer of either Silicone or Teflon gel should applied to each rod. Each pillow block bearing and flange bearing has a grease fittings that must be lubricated regularly. Use general purpose bearing grease and follow the schedule below.

Although cables should be inspected daily, it is important that ALL cables be replaced as directed in the schedule below. Please note that at any first sign of wear the cable should be replaced immediately.

If there are any questions concerning maintenance, please contact your local Batca dealer or contact Batca Fitness Systems directly at:

Batca Fitness Systems
(919) 255-1233
www.batcafitness.com

	DAILY		WEEKLY		MONTHLY		QUARTERLY		YEARS	
	Commercial	Home	Commercial	Home	Commercial	Home	Commercial	Home	Commercial	Home
CLEAN										
FRAME			X			X				
INSPECT										
OVERALL	X	X								
SAFETY DECALS	X	X								
HARDWARE	X	X								
STOPS/SAFETY CATCHES	X	X								
FRAME			X			X				

Limited Lifetime Warranty

What is covered

For Residential Use:

Batca Fitness Systems warrants all of its products against defects in manufacturing, materials and workmanship under normal use and service for one year from date of purchase including paint, chrome, upholstery and grips. Batca Fitness Systems also warrants all cables, belts, bolts, nuts, caps, plugs, bumpers, washers, levelers, decals, gas springs and other hardware for three years after date of purchase; all moving parts, including pulleys, bushings, bearings and pull pins for five years after date of purchase and warrants the frame and all welded parts for the lifetime of the original purchaser.

For Commercial Use:

Batca Fitness Systems warrants all of its products against defects in manufacturing, materials and workmanship under normal use and service for six months from date of purchase including paint, chrome, upholstery and grips. Batca Fitness Systems also warrants all cables, belts, bolts, nuts, caps, plugs, bumpers, washers, levelers, decals, gas springs and other hardware for one year after date of purchase; all moving parts, including pulleys, bushings, bearings and pull pins for three years after date of purchase and warrants the frame and all welded parts for ten years after date of purchase.

What is not covered

This warranty does not cover damage, which results from shipping, misuse, abuse, neglect, carelessness, modification or alteration, accident, fire, flood, "acts of God" or other contingencies beyond the control of Batca Fitness Systems. This warranty also does not cover deterioration from wear and tear or exposure or any defect, which would not have happened if instructions in the owner's manual had been followed. Improper installation, improper assembly or follow-up maintenance along with installation of parts or accessories not originally intended for products of Batca Fitness Systems are also not covered by this warranty. Only genuine Batca parts should be used for replacement, repair, and maintenance for this warranty to apply.

Defective parts will be repaired or replaced at Batca Fitness Systems option, without parts charge to the purchaser. All returns require a return authorization prior to acceptance of repair work. Batca Fitness Systems reserves the right to make design changes without any prior notification and shall not be responsible for incidental or consequential damages.

The purchaser is responsible for shipping the defective part back to the factory. Repair or replacement is the exclusive and sole remedy of the purchaser. Labor charges associated with parts changeovers are not covered by this warranty. Proof of purchase, serial number, model number and date of purchase will be required along with all pertinent information of the alleged damage.

This warranty applies only to the original purchaser and is not transferable. Claims under this warranty must be made directly to Batca Fitness Systems.

Batca Fitness Systems
1207 N. New Hope Road
Raleigh, NC 27610
(919) 255-1233

www.batcafitness.com

Please keep this for your records.



Scan the QR Code to
register your new
BATCA Product online!

Layout Diagram

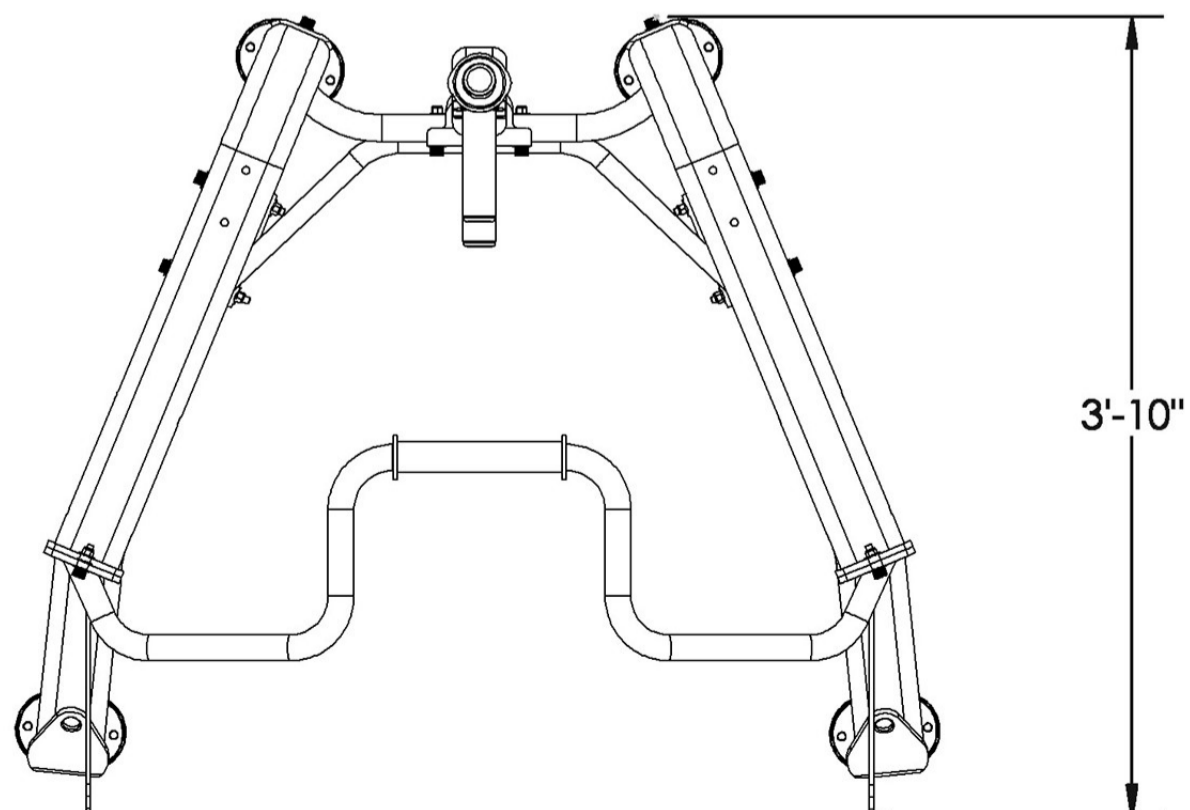
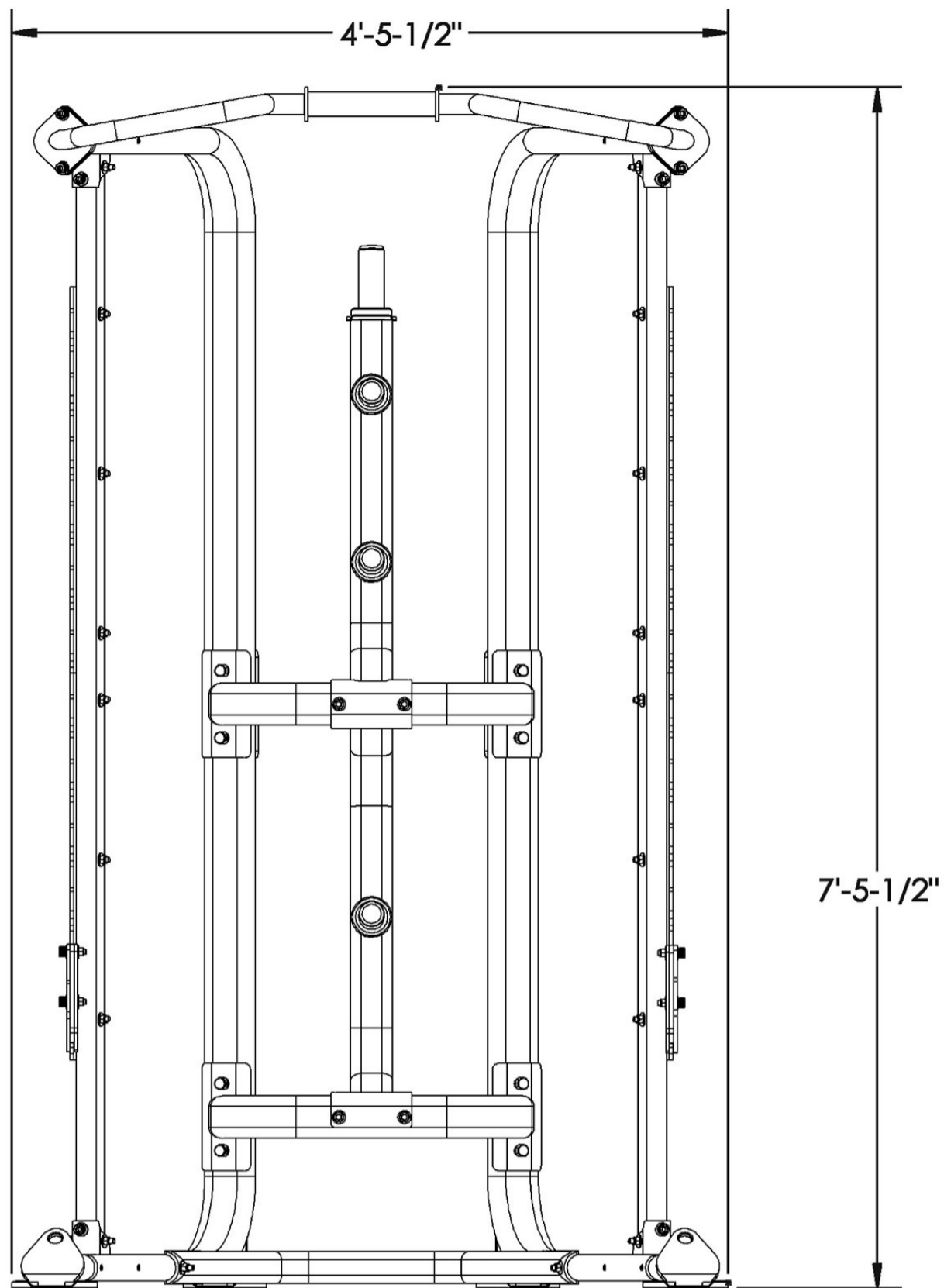

The AXIS Freeweight Rack has a layout dimension of 4-5.5" (Length) x 3'-10" (Width) x 7'-5.5" (Height). There should be minimum of 18", preferably 24" of working space around the entire unit.